



System x3250

Types 4364 and 4365

Installation Guide

Welcome.

Thank you for buying an IBM server. Your server is based on the X-Architecture technology, and it features superior performance, availability, and affordability.

This server *Installation Guide* contains information for setting up and configuring your server.

For detailed information about your server, view the publications on the Documentation CD.

You can also find the most current information about your server at:
<http://www.ibm.com/servers/eserver/support/xseries/index.html/>.

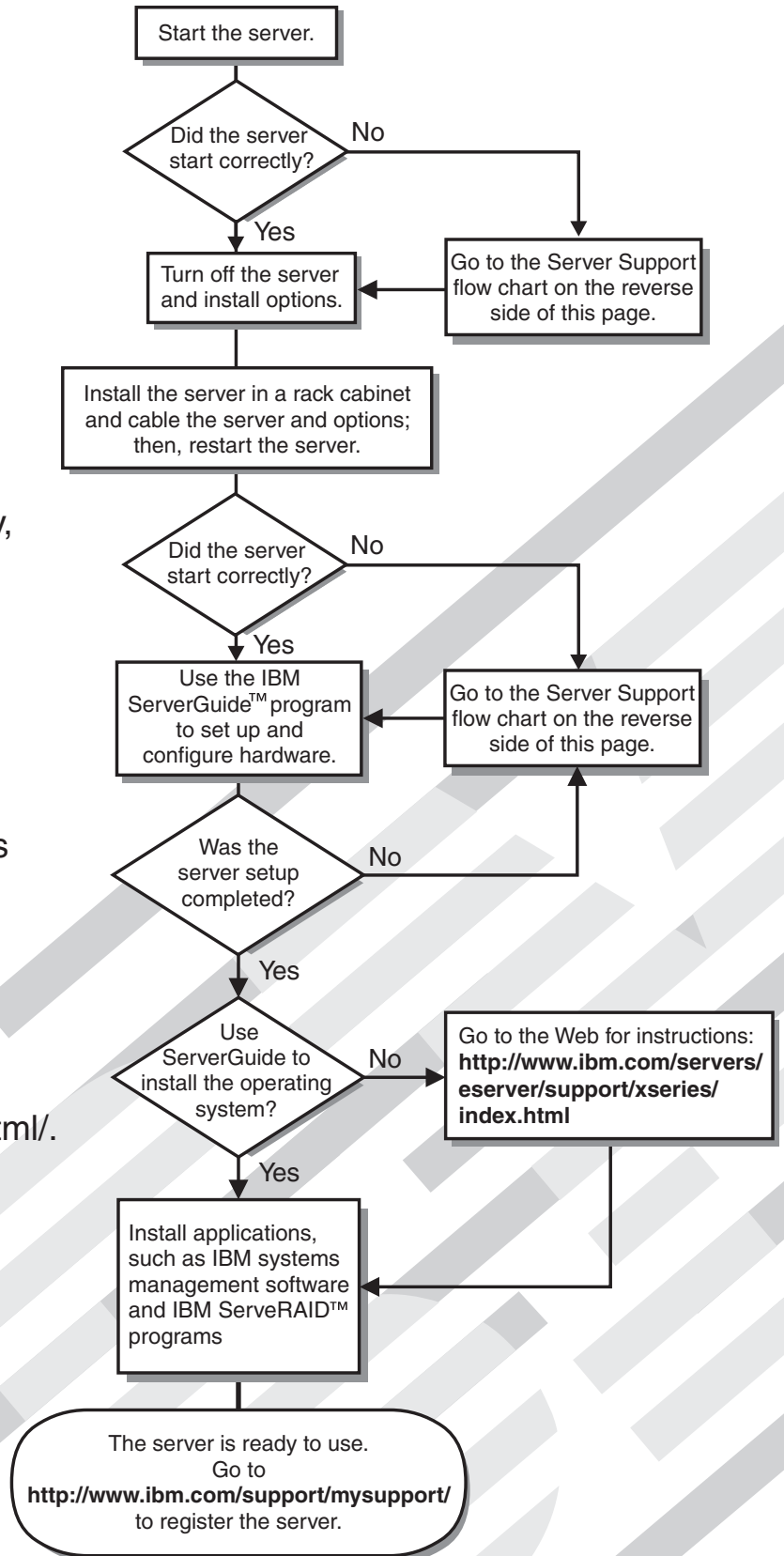

Server Support

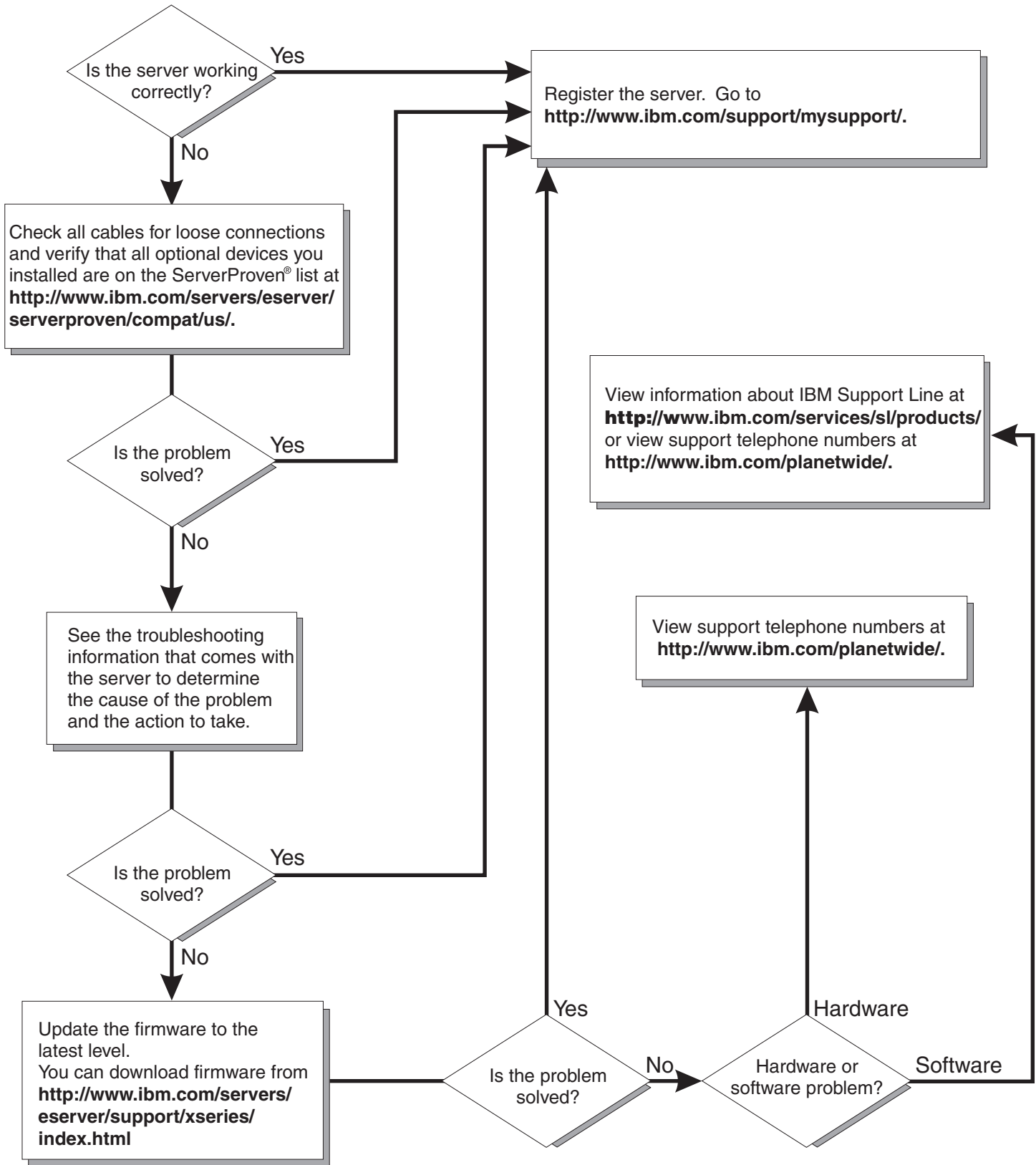

IBM System x3250 Types 4364 and 4365



Installation Guide

Note:

Before using this information and the product it supports, read the general information in Appendix B, "Notices," on page 51 and the *Warranty and Support Information* document on the IBM System x Documentation CD.

Third Edition (January 2007)

© Copyright International Business Machines Corporation 2007. All rights reserved.

US Government Users Restricted Rights – Use, duplication or disclosure restricted by GSA ADP Schedule Contract with IBM Corp.

Contents

Safety	v
Chapter 1. Introduction	1
The IBM System x Documentation CD	2
Hardware and software requirements	2
Using the Documentation Browser	2
Notices and statements in this document	3
Features and specifications	4
Major components of the server	5
System-board optional-device connectors	6
Chapter 2. Installing optional devices	7
Installation guidelines	7
System reliability guidelines	8
Handling static-sensitive devices	8
Removing the cover	9
Installing a memory module	9
Installing a hard disk drive	11
Installing a simple-swap Serial ATA hard disk drive	11
Installing a hot-swap hard disk drive	12
Installing an adapter	13
Installing a Remote Supervisor Adapter II SlimLine	17
Completing the installation	18
Installing the cover	18
Connecting the cables	19
Updating the server configuration	19
Chapter 3. Server controls, LEDs, and power	21
Front view	21
Rear view	22
Server power features	23
Turning on the server	23
Turning off the server	23
Chapter 4. Configuring the server	25
Using the ServerGuide Setup and Installation CD	25
Using the Configuration/Setup Utility program	26
Using the LSI Logic Configuration Utility program	26
Using the baseboard management controller	27
Chapter 5. Solving problems	29
Diagnostic tools overview	29
POST beep codes	29
POST error codes	30
Troubleshooting tables	37
CD or DVD drive problems	37
General problems	38
Hard disk drive problems	38
Intermittent problems	39
Keyboard, mouse, or pointing-device problems	39
Memory problems	40
Microprocessor problems	41
Monitor problems	41

Optional-device problems	44
Power problems	45
Serial port problems	46
ServerGuide problems	46
Software problems	47
Universal Serial Bus (USB) port problems	48
Video problems.	48
Appendix A. Getting help and technical assistance	49
Before you call	49
Using the documentation	49
Getting help and information from the World Wide Web	50
Software service and support	50
Hardware service and support	50
IBM Taiwan product service	50
Appendix B. Notices	51
Trademarks	51
Important notes.	52
Product recycling and disposal	53
Battery return program	54
Electronic emission notices	55
Federal Communications Commission (FCC) statement	55
Industry Canada Class A emission compliance statement	55
Australia and New Zealand Class A statement	55
United Kingdom telecommunications safety requirement.	55
European Union EMC Directive conformance statement.	56
Taiwanese Class A warning statement	56
Chinese Class A warning statement	56
Japanese Voluntary Control Council for Interference (VCCI) statement	56
Index	57

Safety

Before installing this product, read the Safety Information.

قبل تركيب هذا المنتج، يجب قراءة الملاحظات الأمنية

Antes de instalar este produto, leia as Informações de Segurança.

在安装本产品之前，请仔细阅读 **Safety Information** (安全信息)。

安裝本產品之前，請先閱讀「安全資訊」。

Prije instalacije ovog produkta obavezno pročitajte Sigurnosne Upute.

Před instalací tohoto produktu si přečtěte příručku bezpečnostních instrukcí.

Læs sikkerhedsforskrifterne, før du installerer dette produkt.

Lees voordat u dit product installeert eerst de veiligheidsvoorschriften.

Ennen kuin asennat tämän tuotteen, lue turvaohjeet kohdasta Safety Information.

Avant d'installer ce produit, lisez les consignes de sécurité.

Vor der Installation dieses Produkts die Sicherheitshinweise lesen.

Πριν εγκαταστήσετε το προϊόν αυτό, διαβάστε τις πληροφορίες ασφάλειας (safety information).

לפני שתתקינו מוצר זה, קראו את הוראות הבטיחות.

A termék telepítése előtt olvassa el a Biztonsági előírásokat!

Prima di installare questo prodotto, leggere le Informazioni sulla Sicurezza.

製品の設置の前に、安全情報をお読みください。

본 제품을 설치하기 전에 안전 정보를 읽으십시오.

Пред да се инсталира овој продукт, прочитајте информацијата за безбедност.

Les sikkerhetsinformasjonen (Safety Information) før du installerer dette produktet.

Przed zainstalowaniem tego produktu, należy zapoznać się z książką "Informacje dotyczące bezpieczeństwa" (Safety Information).

Antes de instalar este produto, leia as Informações sobre Segurança.

Перед установкой продукта прочтите инструкции по технике безопасности.

Pred inštaláciou tohto zariadenia si pečítajte Bezpečnostné predpisy.

Pred namestitvijo tega proizvoda preberite Varnostne informacije.

Antes de instalar este producto, lea la información de seguridad.

Läs säkerhetsinformationen innan du installerar den här produkten.

Important:

Each caution and danger statement in this document is labeled with a number. This number is used to cross reference an English-language caution or danger statement with translated versions of the caution or danger statement in the *Safety Information* document.

For example, if a caution statement is labeled “Statement 1”, translations for that caution statement are in the *Safety Information* document under “Statement 1”.

Be sure to read all caution and danger statements in this document before you perform the procedures. Read any additional safety information that comes with the server or optional device before you install the device.

Statement 1:



DANGER

Electrical current from power, telephone, and communication cables is hazardous.

To avoid a shock hazard:

- **Do not connect or disconnect any cables or perform installation, maintenance, or reconfiguration of this product during an electrical storm.**
- **Connect all power cords to a properly wired and grounded electrical outlet.**
- **Connect to properly wired outlets any equipment that will be attached to this product.**
- **When possible, use one hand only to connect or disconnect signal cables.**
- **Never turn on any equipment when there is evidence of fire, water, or structural damage.**
- **Disconnect the attached power cords, telecommunications systems, networks, and modems before you open the device covers, unless instructed otherwise in the installation and configuration procedures.**
- **Connect and disconnect cables as described in the following table when installing, moving, or opening covers on this product or attached devices.**

To Connect:

1. Turn everything OFF.
2. First, attach all cables to devices.
3. Attach signal cables to connectors.
4. Attach power cords to outlet.
5. Turn device ON.

To Disconnect:

1. Turn everything OFF.
2. First, remove power cords from outlet.
3. Remove signal cables from connectors.
4. Remove all cables from devices.

Statement 2:



CAUTION:

When replacing the lithium battery, use only IBM® Part Number 33F8354 or an equivalent type battery recommended by the manufacturer. If your system has a module containing a lithium battery, replace it only with the same module type made by the same manufacturer. The battery contains lithium and can explode if not properly used, handled, or disposed of.

Do not:

- **Throw or immerse into water**
- **Heat to more than 100°C (212°F)**
- **Repair or disassemble**

Dispose of the battery as required by local ordinances or regulations.

Statement 3:



CAUTION:

When laser products (such as CD-ROMs, DVD drives, fiber optic devices, or transmitters) are installed, note the following:

- Do not remove the covers. Removing the covers of the laser product could result in exposure to hazardous laser radiation. There are no serviceable parts inside the device.
- Use of controls or adjustments or performance of procedures other than those specified herein might result in hazardous radiation exposure.



DANGER

Some laser products contain an embedded Class 3A or Class 3B laser diode. Note the following.

Laser radiation when open. Do not stare into the beam, do not view directly with optical instruments, and avoid direct exposure to the beam.



Class 1 Laser Product
Laser Klasse 1
Laser Klass 1
Luokan 1 Laserlaite
Appareil À Laser de Classe 1

Statement 4:



≥ 18 kg (39.7 lb)



≥ 32 kg (70.5 lb)

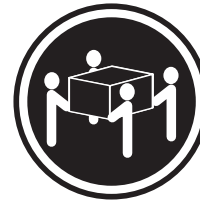

≥ 55 kg (121.2 lb)

CAUTION:

Use safe practices when lifting.

Statement 5:



CAUTION:

The power control button on the device and the power switch on the power supply do not turn off the electrical current supplied to the device. The device also might have more than one power cord. To remove all electrical current from the device, ensure that all power cords are disconnected from the power source.



Statement 8:



CAUTION:

Never remove the cover on a power supply or any part that has the following label attached.



Hazardous voltage, current, and energy levels are present inside any component that has this label attached. There are no serviceable parts inside these components. If you suspect a problem with one of these parts, contact a service technician.

Statement 26:



CAUTION:

Do not place any object on top of rack-mounted devices.



This server is suitable for use on an IT power-distribution system whose maximum phase-to-phase voltage is 240 V under any distribution fault condition.

Chapter 1. Introduction

This *Installation Guide* contains instructions for setting up your IBM System x3250 Type 4364 or 4365 server and basic instructions for installing some optional devices. More detailed instructions for installing optional devices are in the *User's Guide* on the IBM System x™ *Documentation CD*, which comes with the server. This document contains information about:

- Setting up and cabling the server
- Starting and configuring the server
- Installing some optional devices
- Solving problems

If firmware and documentation updates are available, you can download them from the IBM Web site. The server might have features that are not described in the documentation that comes with the server, and the documentation might be updated occasionally to include information about those features, or technical updates might be available to provide additional information that is not included in the server documentation. To check for updates, go to <http://www.ibm.com/servers/eserver/support/xseries/index.html>, select **System x3250** from the **Hardware** list, and click **Go**. For firmware updates, click the **Download** tab. For documentation updates, click the **Install and use** tab, and click **Product documentation**.

Note: Changes are made periodically to the IBM Web site. Procedures for locating firmware and documentation might vary slightly from what is described in this document.

The server comes with an IBM *ServerGuide™ Setup and Installation* CD to help you configure the hardware, install device drivers, and install the operating system.

The server comes with a limited warranty. You can obtain up-to-date information about the server and other IBM server products at <http://www.ibm.com/systems/x/>.

Record information about the server in the following table. You will need this information when you register the server with IBM.

Product name	IBM System x3250 server
Machine type	4364 or 4365 (circle the machine type that applies)
Model number	_____
Serial number	_____

The model number and serial number are on the ID label on the bezel, as shown in the following illustration.

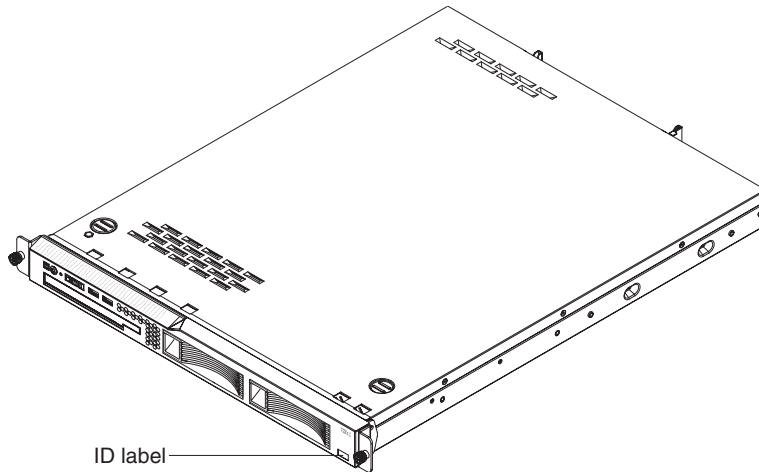

Note: This illustration shows a serial-attached SCSI (SAS) hot-swap hard disk drive model (3.5-inch drives). A Serial ATA (SATA) hot-swap hard disk drive model (3.5-inch drives), SATA simple-swap hard disk drive model (3.5-inch drives), and a SAS hot-swap model with 2.5-inch hard disk drives are also available. This illustration might differ slightly from your hardware.

For a list of supported optional devices for the server, see <http://www.ibm.com/servers/eserver/serverproven/compat/us/>.

See the *Rack Installation Instructions* document for complete rack installation and removal instructions.

The IBM System x Documentation CD

The IBM *System x Documentation* CD contains documentation for the server in Portable Document Format (PDF) and includes the IBM Documentation Browser to help you find information quickly.

Hardware and software requirements

The IBM *System x Documentation* CD requires the following minimum hardware and software:

- Microsoft Windows XP, Windows 2000, or Red Hat Linux
- 100 MHz microprocessor
- 32 MB of RAM
- Adobe Acrobat Reader 3.0 (or later) or xpdf, which comes with Linux operating systems

Using the Documentation Browser

Use the Documentation Browser to browse the contents of the CD, read brief descriptions of the documents, and view documents, using Adobe Acrobat Reader or xpdf. The Documentation Browser automatically detects the regional settings in your server and displays the documents in the language for that region (if available). If a document is not available in the language for that region, the English-language version is displayed.

Use one of the following procedures to start the Documentation Browser:

- If Autostart is enabled, insert the CD into the CD drive. The Documentation Browser starts automatically.
- If Autostart is disabled or is not enabled for all users, use one of the following procedures:
 - If you are using a Windows operating system, insert the CD into the CD drive and click **Start --> Run**. In the **Open** field, type
`e:\win32.bat`

 where *e* is the drive letter of the CD drive, and click **OK**.
 - If you are using Red Hat Linux, insert the CD into the CD drive; then, run the following command from the `/mnt/cdrom` directory:
`sh runlinux.sh`

Select your server from the **Product** menu. The **Available Topics** list displays all the documents for your server. Some documents might be in folders. A plus sign (+) indicates each folder or document that has additional documents under it. Click the plus sign to display the additional documents.

When you select a document, a description of the document is displayed under **Topic Description**. To select more than one document, press and hold the Ctrl key while you select the documents. Click **View Book** to view the selected document or documents in Acrobat Reader or xpdf. If you selected more than one document, all the selected documents are opened in Acrobat Reader or xpdf.

To search all the documents, type a word or word string in the **Search** field and click **Search**. The documents in which the word or word string appears are listed in order of the most occurrences. Click a document to view it, and press Ctrl+F to use the Acrobat search function or Alt+F to use the xpdf search function within the document.

Click **Help** for detailed information about using the Documentation Browser.

Notices and statements in this document

The caution and danger statements in this document are also in the multilingual *Safety Information* document, which is on the IBM *System x Documentation* CD. Each statement is numbered for reference to the corresponding statement in the *Safety Information* document.

The following notices and statements are used in this document:

- **Note:** These notices provide important tips, guidance, or advice.
- **Important:** These notices provide information or advice that might help you avoid inconvenient or problem situations.
- **Attention:** These notices indicate potential damage to programs, devices, or data. An attention notice is placed just before the instruction or situation in which damage could occur.
- **Caution:** These statements indicate situations that can be potentially hazardous to you. A caution statement is placed just before the description of a potentially hazardous procedure step or situation.
- **Danger:** These statements indicate situations that can be potentially lethal or extremely hazardous to you. A danger statement is placed just before the description of a potentially lethal or extremely hazardous procedure step or situation.

Features and specifications

The following information is a summary of the features and specifications of the server. Depending on the server model, some features might not be available, or some specifications might not apply.

Racks are marked in vertical increments of 4.45 cm (1.75 inches). Each increment is referred to as a unit, or “U.” A 1-U-high device is 1.75 inches tall.

Table 1. Features and specifications

<p>Microprocessor: One Intel® LGA 775 Xeon 3000 series, Pentium® D, or Celeron D, depending on the server model Note: Use the Configuration/Setup Utility program to determine the size of the L2 cache, speed of the microprocessor, and speed of the front-side bus.</p> <p>Memory:</p> <ul style="list-style-type: none"> • Minimum: One or two 512 MB DIMMs, depending on the server model • Maximum: 8 GB • Type: PC2-5300, 667 MHz, ECC, DDR II unbuffered SDRAM DIMMs only • Slots: Four dual inline • Supports 512 MB, 1 GB, and 2 GB DIMMs <p>Drives: Ultrabay Enhanced: CD or CD/DVD</p> <p>Expansion bays: One of the following configurations:</p> <ul style="list-style-type: none"> • Two 3.5-inch slim-high bays for hard disk drives. <ul style="list-style-type: none"> – Hot-swap models: Supports maximum of two serial-attached SCSI (SAS) drives or two serial ATA (SATA) drives. – Simple-swap models: Supports maximum of two SATA drives • Four 2.5-inch small form-factor (SFF) hot-swap bays for hard disk drives. Supports a maximum of four 2.5-inch SAS drives. <p>Expansion slots: Two PCI Express x8 slots, one low-profile and one 3/4-length full height</p> <p>Video controller:</p> <ul style="list-style-type: none"> • ATI ES1000 video on system board • 16 MB DDR video memory 	<p>Power supply: 351 watt (110 or 220 V ac auto-sensing)</p> <p>Size:</p> <ul style="list-style-type: none"> • Height: 43 mm (1.75 inches, 1 U) • Depth: 559 mm (22 inches) • Width: 440 mm (17.32 inches) • Maximum weight: 12.7 kg (28 lb) depending on your configuration <p>Integrated functions:</p> <ul style="list-style-type: none"> • Two Broadcom NetXtreme™ GB Ethernet controllers on the system board with Wake on LAN® support • Serial port • Four USB ports (two on front and two on rear of server) • Keyboard port • Mouse port • Systems-management port if an optional Remote Supervisor Adapter II SlimLine is installed <p>Hard disk controllers:</p> <ul style="list-style-type: none"> • Serial ATA (SATA) controller (simple-swap SATA models) • Serial-attached SCSI (SAS) controller with integrated RAID (hot-swap SAS/SATA models) <p>Environment:</p> <ul style="list-style-type: none"> • Air temperature: <ul style="list-style-type: none"> – Server on: 10° to 35°C (50.0° to 95.0°F); altitude: 0 to 914.4 m (3000 ft) – Server on: 10° to 32°C (50.0° to 89.6°F); altitude: 914.4 m (3000 ft) to 2133 m (6998.0 ft) – Server off: 10° to 43°C (50.0° to 109.4°F); maximum altitude: 2133 m (6998.0 ft) – Shipping: -40° to 60°C (-40° to 140°F); maximum altitude: 2133 m (6998.0 ft) • Humidity: <ul style="list-style-type: none"> – Server on: 8% to 80% – Server off: 8% to 80% 	<p>Acoustical noise emissions:</p> <ul style="list-style-type: none"> • Sound power, idling: 6.5 bel maximum • Sound power, operating: 6.5 bel maximum <p>Heat output: Approximate heat output in British thermal units (Btu) per hour:</p> <ul style="list-style-type: none"> • Minimum configuration: 341 Btu per hour (100 watts) • Maximum configuration: 1024 Btu per hour (300 watts) <p>Electrical input:</p> <ul style="list-style-type: none"> • Sine-wave input (47 - 63 Hz) required • Input voltage low range: <ul style="list-style-type: none"> – Minimum: 100 V ac – Maximum: 127 V ac • Input voltage high range: <ul style="list-style-type: none"> – Minimum: 200 V ac – Maximum: 240 V ac • Approximate input kilovolt-amperes (kVA): <ul style="list-style-type: none"> – Minimum: 0.102 kVA – Maximum: 0.55 kVA <p>Notes:</p> <ol style="list-style-type: none"> 1. Power consumption and heat output vary depending on the number and type of optional features that are installed and the power-management optional features that are in use. 2. These levels were measured in controlled acoustical environments according to the procedures that are specified by the American National Standards Institute (ANSI) S12.10 and ISO 7779 and are reported in accordance with ISO 9296. Actual sound-pressure levels in a given location might exceed the average stated values because of room reflections and other nearby noise sources. The declared sound-power levels indicate an upper limit, below which a large number of computers will operate.
--	--	---

Major components of the server

Blue on a component indicates touch points, where you can grip the component to remove it from or install it in the server, open or close a latch, and so on.

Orange on a component or an orange label on or near a component indicates that the component can be hot-swapped, which means that if the server and operating system support hot-swap capability, you can remove or install the component while the server is running. (Orange can also indicate touch points on hot-swap components.) See the instructions for removing or installing a specific hot-swap component for any additional procedures that you might have to perform before you remove or install the component.

The following illustration shows the major components in the server.

Note: The illustrations in this document might differ slightly from your hardware.

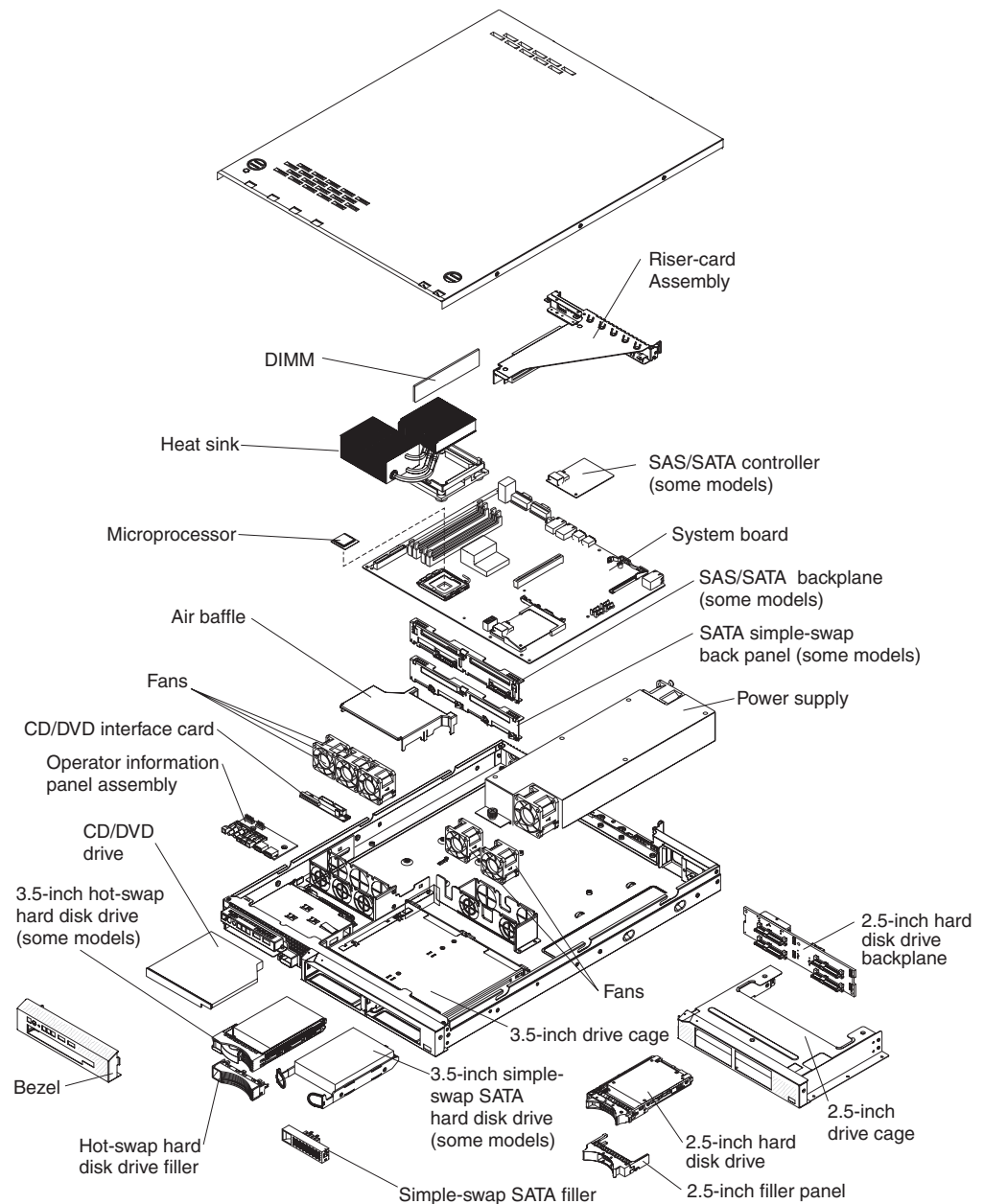

System-board optional-device connectors

The following illustration shows the connectors for user-installable optional devices.

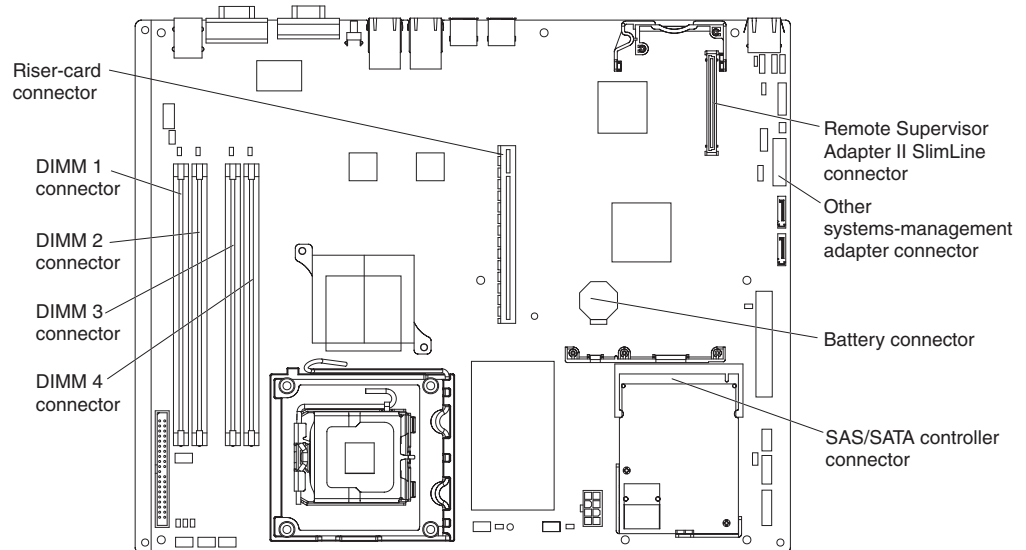

The following illustration shows the location of the PCI Express slots on the riser-card assembly.

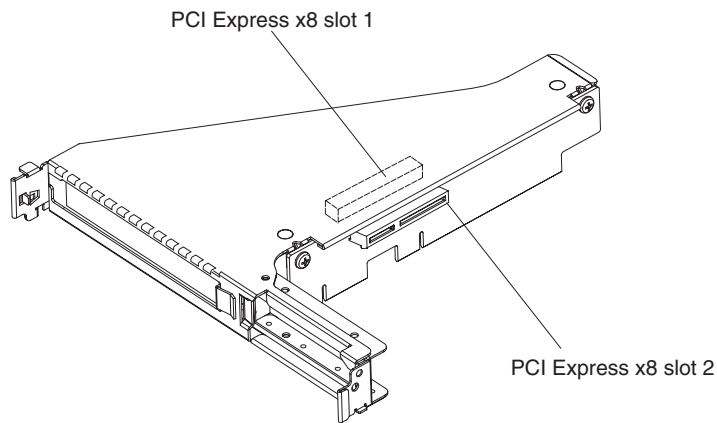

Chapter 2. Installing optional devices

This chapter provides basic instructions for installing optional hardware devices in the server. These instructions are intended for users who are experienced with setting up IBM server hardware.

Installation guidelines

Before you install optional devices, read the following information:

- Read the safety information that begins on page v and the guidelines in “Handling static-sensitive devices” on page 8. This information will help you work safely.
- When you install your new server, take the opportunity to download and apply the most recent firmware updates. This step will help to ensure that any known issues are addressed and that your server is ready to function at maximum levels of performance. To download firmware updates for your server, go to <http://www.ibm.com/servers/eserver/support/xseries/index.html>, select **System x3250** from the **Hardware** list, click **Go**, and then click the **Download** tab. For additional information about tools for updating, managing, and deploying firmware, see the System x and xSeries Tools Center at <http://publib.boulder.ibm.com/infocenter/toolsctr/v1r0/index.jsp>.
- Before you install optional hardware devices, make sure that the server is working correctly. Start the server, and make sure that the operating system starts, if an operating system is installed, or that a 19990305 error code is displayed, indicating that an operating system was not found but the server is otherwise working correctly. If the server is not working correctly, see Chapter 5, “Solving problems,” on page 29 for diagnostic information.
- Observe good housekeeping in the area where you are working. Place removed covers and other parts in a safe place.
- If you must start the server while the cover is removed, make sure that no one is near the server and that no tools or other objects have been left inside the server.
- Do not attempt to lift an object that you think is too heavy for you. If you have to lift a heavy object, observe the following precautions:
 - Make sure that you can stand safely without slipping.
 - Distribute the weight of the object equally between your feet.
 - Use a slow lifting force. Never move suddenly or twist when you lift a heavy object.
 - To avoid straining the muscles in your back, lift by standing or by pushing up with your leg muscles.
- Make sure that you have an adequate number of properly grounded electrical outlets for the server, monitor, and other devices.
- Back up all important data before you make changes to disk drives.
- Have a small flat-blade screwdriver available.
- You do not have to turn off the server to install or replace hot-plug Universal Serial Bus (USB) devices.
- Blue on a component indicates touch points, where you can grip the component to remove it from or install it in the server, open or close a latch, and so on.
- Orange on a component or an orange label on or near a component indicates that the component can be hot-swapped, which means that if the server and operating system support hot-swap capability, you can remove or install the

component while the server is running. (Orange can also indicate touch points on hot-swap components.) See the instructions for removing or installing a specific hot-swap component for any additional procedures that you might have to perform before you remove or install the component.

- When you are finished working on the server, reinstall all safety shields, guards, labels, and ground wires.
- For a list of supported optional devices for the server, see <http://www.ibm.com/servers/eserver/serverproven/compat/us/>.

System reliability guidelines

To help ensure proper cooling and system reliability, make sure that the following requirements are met:

- Each of the drive bays has a drive or a filler panel and electromagnetic compatibility (EMC) shield installed in it.
- If the server has redundant power, each of the power-supply bays has a power supply installed in it.
- There is adequate space around the server to allow the server cooling system to work properly. Leave approximately 50 mm (2.0 in.) of open space around the front and rear of the server. Do not place objects in front of the fans. For proper cooling and airflow, replace the server cover before turning on the server. Operating the server for extended periods of time (more than 30 minutes) with the server cover removed might damage server components.
- You have followed the cabling instructions that come with optional adapters.
- You have replaced a failed fan within 48 hours.
- You have replaced a hot-swap drive within 2 minutes of removal.

Handling static-sensitive devices

Attention: Static electricity can damage the server and other electronic devices. To avoid damage, keep static-sensitive devices in their static-protective packages until you are ready to install them.

To reduce the possibility of damage from electrostatic discharge, observe the following precautions:

- Limit your movement. Movement can cause static electricity to build up around you.
- The use of a grounding system is recommended. For example, wear an electrostatic-discharge wrist strap, if one is available.
- Handle the device carefully, holding it by its edges or its frame.
- Do not touch solder joints, pins, or exposed circuitry.
- Do not leave the device where others can handle and damage it.
- While the device is still in its static-protective package, touch it to an unpainted metal surface on the outside of the server for at least 2 seconds. This drains static electricity from the package and from your body.
- Remove the device from its package and install it directly into the server without setting down the device. If it is necessary to set down the device, put it back into its static-protective package. Do not place the device on the server cover or on a metal surface.
- Take additional care when you handle devices during cold weather. Heating reduces indoor humidity and increases static electricity.

Removing the cover

To remove the cover, complete the following steps:

1. Read the safety information that begins on page v and “Installation guidelines” on page 7.
2. Turn off the server and all attached devices.
3. Disconnect all external cables and power cords.

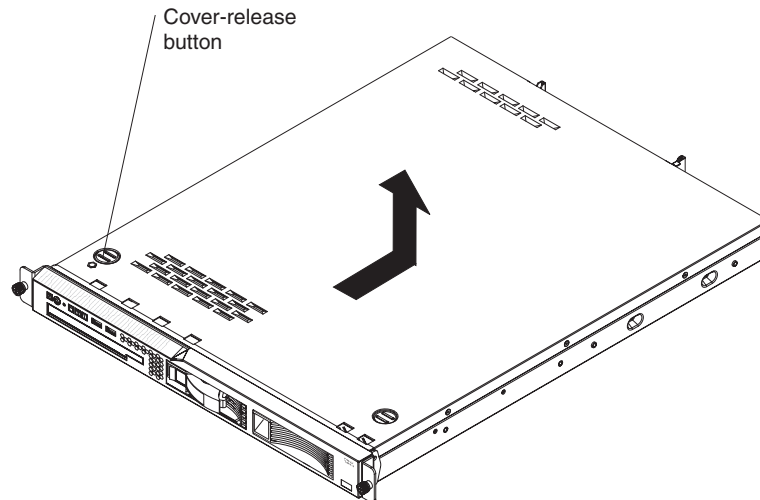

4. Press the cover-release button.
5. Slide the cover back approximately 1.27 cm (0.5 inches); then, lift it off the server.

Attention: For proper cooling and airflow, replace the cover before turning on the server. Operating the server for extended periods of time (more than 30 minutes) with the cover removed might damage server components.

Installing a memory module

The following notes describe the types of dual inline memory modules (DIMMs) that the server supports and other information that you must consider when installing DIMMs:

- The server supports 512 MB, 1 GB, and 2 GB DIMMs, for a maximum of 8 GB of system memory. See <http://www.ibm.com/servers/eserver/serverproven/compat/us/> for a list of memory modules that you can use with the server.
- The amount of usable memory will be reduced depending on the system configuration. A certain amount of memory must be reserved for system resources. Use the system summary in the Configuration/Setup Utility program to view the total amount of installed memory and the amount of configured memory (see “Using the Configuration/Setup Utility program” on page 26).
- The server comes with one 512 MB DIMM installed in DIMM connector 1. Some models come with a second 512 MB DIMM installed in DIMM connector 3. If one DIMM is installed, when you install an additional DIMM, it must be installed in DIMM connector 3, and it must be the same size, speed, type, and technology as the DIMM that is installed in DIMM connector 1. You can mix compatible DIMMs from various manufacturers. The third and fourth DIMMs must be installed as a pair, in DIMM connectors 2 and 4.
- If you install a pair of DIMMs in DIMM connectors 2 and 4, they do not have to be the same size, speed, type, and technology as the DIMMs that are installed in

DIMM connectors 1 and 3. However, the size, speed, type, and technology of the DIMMs that you install in DIMM connectors 2 and 4 must match each other.

- Install only double-data-rate II (DDR II), PC2-5300, unbuffered synchronous dynamic random-access memory (SDRAM) with error correcting code (ECC) DIMMs. These DIMMs must be compatible with the latest PC2-5300 SDRAM unbuffered DIMM specification.
- If you install a pair of 2 GB DIMMs and a pair of other-size DIMMs, the 2 GB DIMMs must be installed as the first pair (in DIMM connectors 1 and 3).
- When you restart the server after you add or remove a DIMM, a message is displayed indicating that the memory configuration has changed.

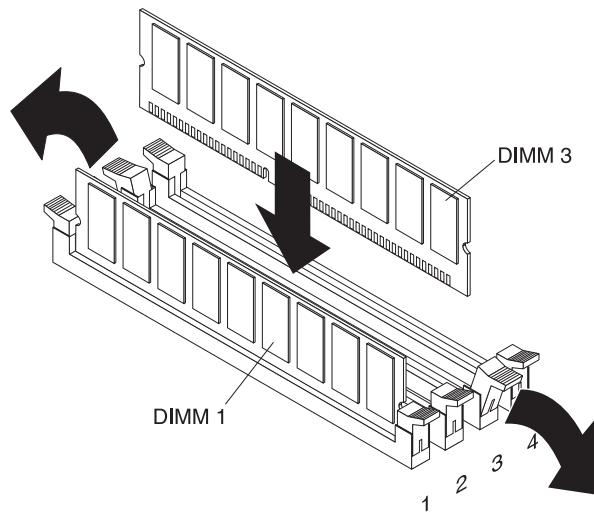

To install a DIMM, complete the following steps:

1. Read the safety information that begins on page v and “Installation guidelines” on page 7.
2. Turn off the server and peripheral devices, and disconnect the power cord and all external cables. Remove the cover.
Attention: To avoid breaking the retaining clips or damaging the DIMM connectors, open, and close the clips gently.
3. Open the retaining clip on each end of the DIMM connector.
4. Touch the static-protective package that contains the DIMM to any unpainted metal surface on the outside of the server. Then, remove the DIMM from the package.
5. Turn the DIMM so that the keys align correctly with the slot.
6. Insert the DIMM into the connector by aligning the edges of the DIMM with the slots at each end of the DIMM connector. Firmly press the DIMM straight down into the connector by applying pressure on both ends of the DIMM simultaneously. The retaining clips snap into the locked position when the DIMM is firmly seated in the connector. If there is a gap between the DIMM and the retaining clips, the DIMM has not been correctly inserted; open the retaining clips, remove the DIMM, and then reinsert it.

If you have other devices to install, do so now. Otherwise, go to “Completing the installation” on page 18.

Installing a hard disk drive

Locate the documentation that comes with the hard disk drive and follow those instructions in addition to the instructions in this chapter.

Note: The ID for an installed hard disk drive is on the front of the server next to the bay that contains the drive.

Table 2. Locations of hard disk drive IDs

3.5-inch drive model servers

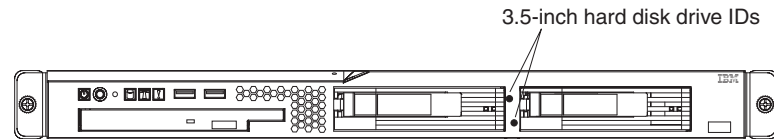

2.5-inch drive model servers

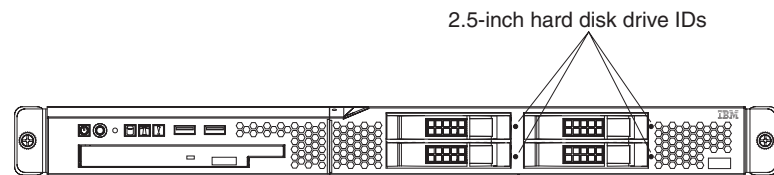

Attention: To avoid damage to the hard disk drive connectors, make sure that the cover is in place and fully closed whenever you install or remove a hard disk drive.

Installing a simple-swap Serial ATA hard disk drive

Attention: Simple-swap hard disk drives are not hot-swappable. Disconnect all power from the server before removing or installing a simple-swap hard disk drive.

To install a simple-swap Serial ATA hard disk drive, complete the following steps.

Note: If you have only one hard disk drive, install it in the left drive bay.

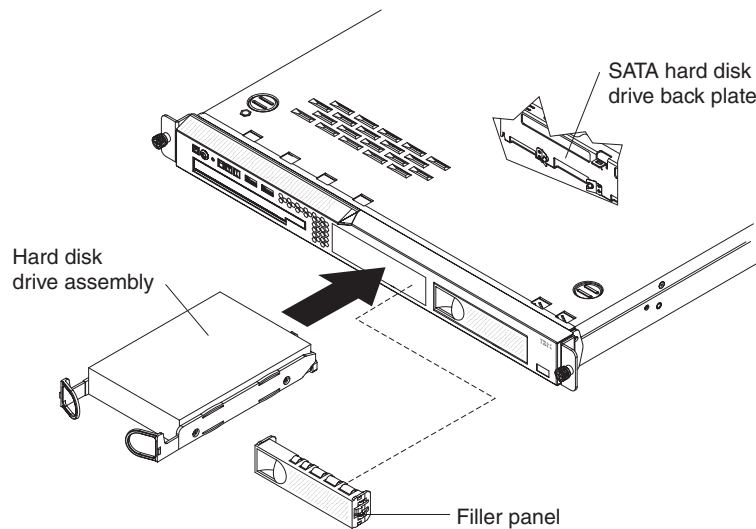

Attention: To avoid damage to the hard disk drive connectors, make sure that the cover is in place and fully closed whenever you install or remove a hard disk drive.

1. Read the safety information that begins on page v and “Installation guidelines” on page 7.

2. Make sure that the server cover is in place and fully closed.
3. Turn off the server and peripheral devices, and disconnect the power cord and all external cables.
4. Remove the filler panel from the bay.
5. Pull the loops of the tray toward each other and slide the drive into the server until the drive connects to the back panel.
6. Insert the filler panel into the bay to cover the drive.

Notes:

1. If the server has a RAID controller or adapter, you might have to reconfigure the disk arrays after you install hard disk drives. See the information on your RAID controller documentation.
2. To remove a simple-swap SATA drive from the bay, make sure that the server is turned off and the power cord is removed; then, remove the filler panel, pull the loops of the drive tray toward each other and pull the tray out of the bay.

If you have other devices to install, do so now. Otherwise, go to “Completing the installation” on page 18.

Installing a hot-swap hard disk drive

The 3.5-inch drive hot-swap server models support either two SAS 3.5-inch hard disk drives or two SATA 3.5-inch hard disk drives. The 2.5-inch drive hot-swap server models support four 2.5-inch SAS hard disk drives.

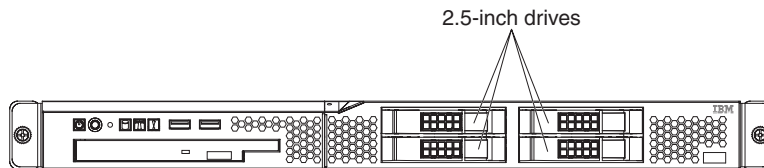

The installation procedure is the same for any of these drives. The illustrations in this procedure show 3.5-inch SAS drives.

To install a hot-swap hard disk drive, complete the following steps:

Note: If you have only one hard disk drive, install it in the left or upper-left drive bay.

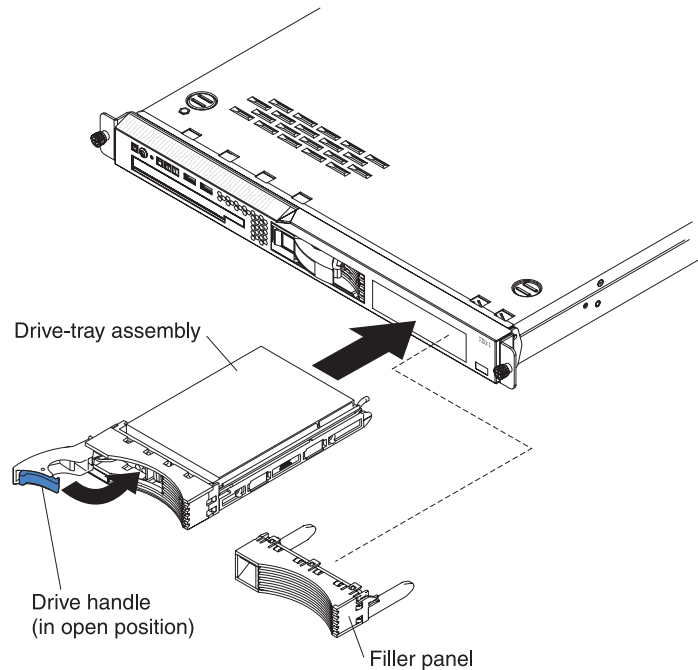

Attention: To avoid damage to the hard disk drive connectors, make sure that the cover is in place and fully closed whenever you install or remove a hard disk drive.

1. Read the safety information that begins on page v and “Installation guidelines” on page 7.
2. Make sure that the server cover is in place and fully closed.
3. Remove the filler panel from the bay. Store it in a safe place for possible future use.

Attention: To maintain proper system cooling, do not operate the server for more than 10 minutes without either a drive or filler panel installed in each bay.

4. Open the drive tray handle.
5. Gently push the drive assembly into the bay until the drive stops.
6. Close the drive tray handle.
7. Check the hard disk drive status LED to make sure that the hard disk drive is operating correctly. If the amber hard disk drive status LED for a drive is lit continuously, that drive is faulty and needs to be replaced. If the green hard disk drive activity LED is flashing, the drive is being accessed.

If you have other devices to install, do so now. Otherwise, go to “Completing the installation” on page 18.

Installing an adapter

The following notes describe the types of adapters that the server supports and other information that you must consider when you install an adapter:

- Because of mechanical interference, when the optional Remote Supervisor Adapter II SlimLine is installed in the server, you cannot install an adapter in expansion slot 1.
- Locate the documentation that comes with the adapter and follow those instructions in addition to the instructions in this section. If you have to change switch settings or jumper settings on the adapter, follow the instructions that come with the adapter.

- The adapter slots are on the riser-card assembly. You must first remove the riser-card assembly to access the adapter slots.
- The two PCI Express slots on the riser-card assembly support PCI Express x8 1.0a adapters.
- You can install one full-height three-quarter-length adapter in expansion slot 1 and one low-profile half-length adapter in expansion slot 2.
- The optional Remote Supervisor Adapter II SlimLine can be installed only in the dedicated connector on the system board (see “System-board optional-device connectors” on page 6 for the location of the connector). To install the Remote Supervisor Adapter II SlimLine, see “Installing a Remote Supervisor Adapter II SlimLine” on page 17.
- The server uses a rotational interrupt technique to configure PCI Express adapters so that you can install PCI Express adapters that do not support sharing of interrupts.
- An optional ServeRAID™ 8s controller provides RAID level 5 support to the hot-swap drives. A ServeRAID 8s controller supports the 2.5-inch hard disk drives without modification. To use a ServeRAID 8s controller with hot-swap 3.5-inch drives, you must connect it to the hard disk drive backplane with a SAS signal cable that is 58 cm (22.8 in.) long. See <http://www.ibm.com/servers/eserver/serverproven/compat/us/> for information about ordering the cable.
- An optional IBM SAS HBA Controller adapter enables you to connect external storage devices, such as SAS or SATA hard disk drives or tape drives, to a simple-swap SATA model server.
- The server scans the PCI slots to assign system resources. The scan sequence is related to the startup sequence. If you have not changed the default startup sequence, the server scans the PCI slots in the following order: the integrated Ethernet controllers 1 and 2; then, the drives connected to the SAS/SATA controller; then, the PCI Express slots 1 and 2.

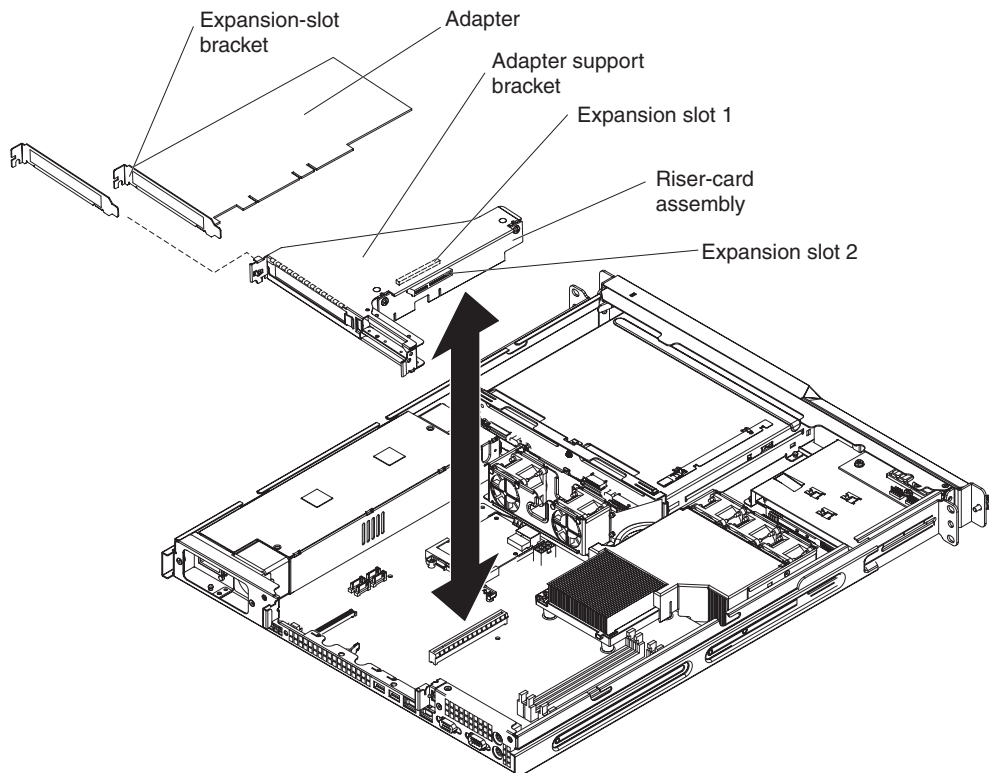

To install an adapter, complete the following steps:

1. Read the safety information that begins on page v and “Installation guidelines” on page 7.
2. Turn off the server and peripheral devices, and disconnect the power cord and all external cables. Remove the cover.
3. Grasp the riser card at the rear edge and lift to remove the riser-card assembly. Place the riser-card assembly on a flat, static-protective surface.

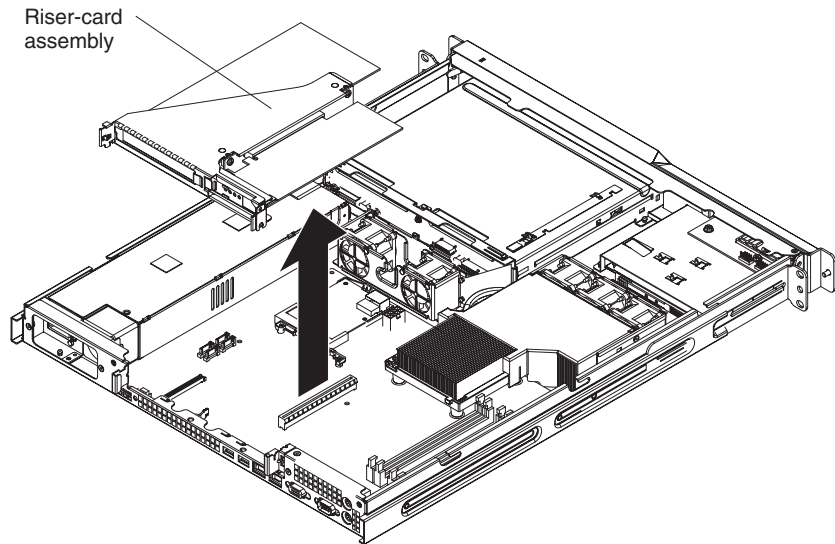

4. Remove the expansion-slot cover on the slot that you intend to use.
Attention: PCI expansion-slot covers must be installed on all vacant slots. This maintains the electronic emissions characteristics of the server and ensures proper cooling of server components.
5. Follow the instructions that come with the adapter to set any jumpers or switches.
Attention: When you install an adapter, make sure that it is completely and correctly seated in the expansion slot in the riser card. Incomplete insertion might cause damage to the riser card, system board, or the adapter when you turn on the server.
6. Carefully grasp the adapter by its top edge or upper corners and align it with the expansion slot in the riser card assembly; then, press the adapter *firmly* into the expansion slot.
7. Follow the cabling instructions, if any, that come with the adapter.
8. Reinstall the riser-card assembly. Make sure that the riser-card assembly is fully seated in the riser-card connectors on the system board.
9. If you are installing a ServeRAID 8s controller, complete the following steps:
 - a. Disconnect the existing SAS/SATA controller signal cable from the hard disk drive backplane and from the controller; then, remove the cable from the server.
 - b. In a server with 2.5 inch drives, route the ServeRAID 8s signal cable as shown in the following illustration and connect it to the hard disk drive backplane.

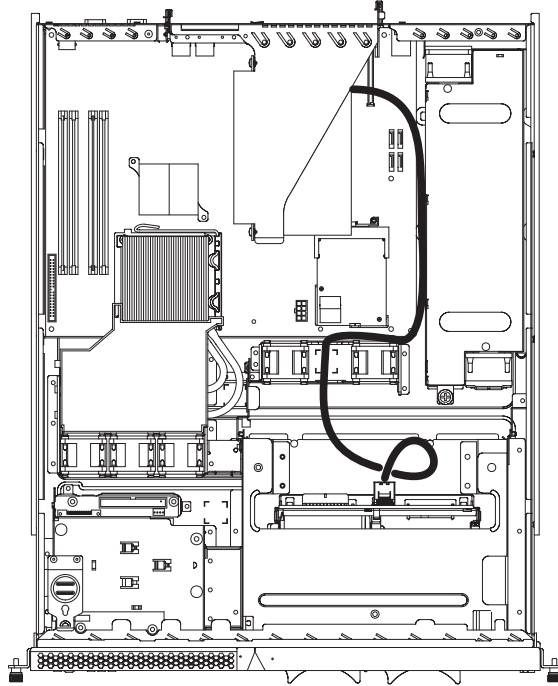

- c. In a server with 3.5 inch drives, route the ServerRAID 8s signal cable as shown in the following illustration and connect it to the hard disk drive backplane.

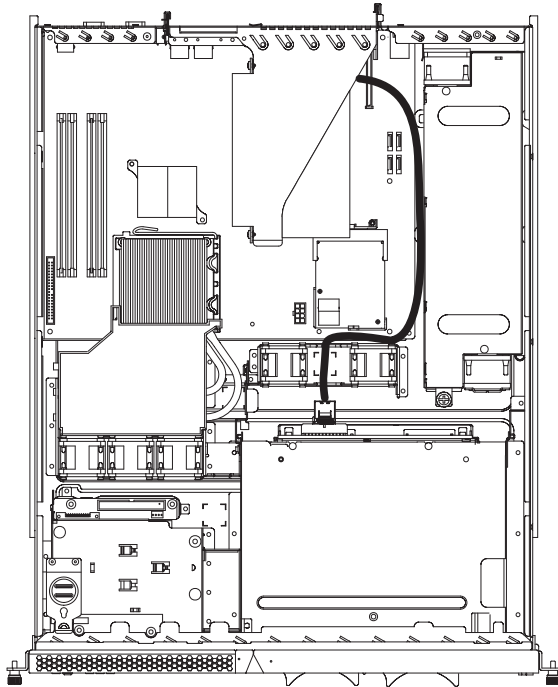

If you have other devices to install, do so now. Otherwise, go to “Completing the installation” on page 18.

Installing a Remote Supervisor Adapter II SlimLine

Install an optional Remote Supervisor Adapter II SlimLine in the Remote Supervisor Adapter II SlimLine connector on the system board. See the illustration in “System-board optional-device connectors” on page 6 for the location of the connector. After the Remote Supervisor Adapter II SlimLine is installed, the systems-management port on the rear of the server is active.

Because of mechanical interference, when the Remote Supervisor Adapter II SlimLine is installed in the server, you cannot install an adapter in expansion slot 1.

Notes:

1. When you start the server for the first time after you install a Remote Supervisor Adapter II SlimLine, the startup process will take several minutes longer than a typical startup.
2. Earlier versions of the Remote Supervisor Adapter II SlimLine might not work in this server. See <http://www.ibm.com/servers/eserver/serverproven/compat/us/> for information about the supported Remote Supervisor Adapter II SlimLine.

To install a Remote Supervisor Adapter II SlimLine, complete the following steps.

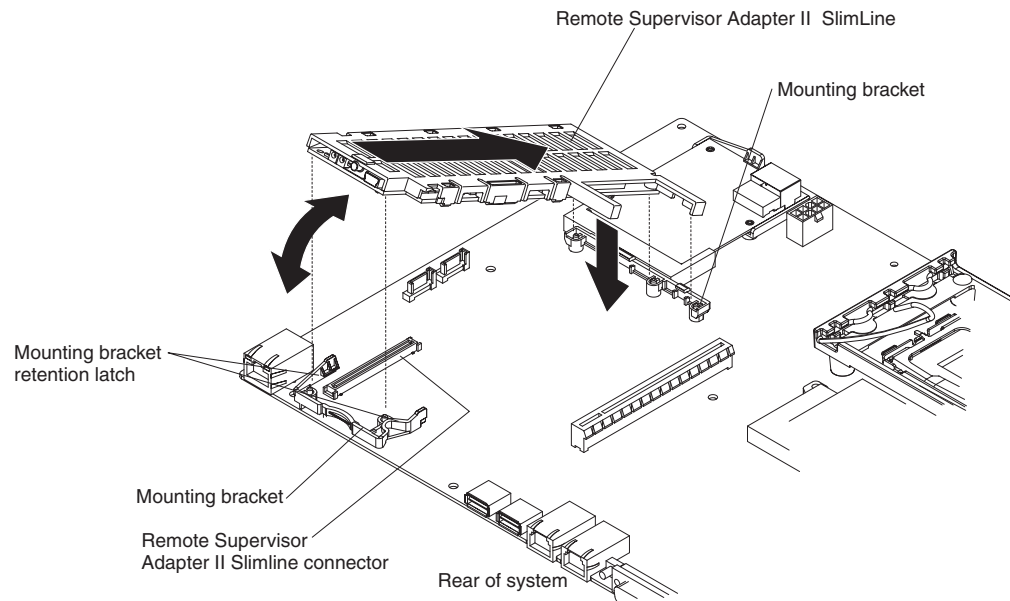

1. Read the safety information that begins on page v and “Installation guidelines” on page 7.
2. Turn off the server and peripheral devices, and disconnect the power cord and all external cables. Remove the cover.
3. Grasp the riser-card assembly at the rear edge and lift to remove it from the server. Place the riser-card assembly on a flat, static-protective surface.
4. Put the protective plastic cover that came with the adapter on the Remote Supervisor Adapter II SlimLine.
5. Turn the Remote Supervisor Adapter II SlimLine so that the keys on the connector align correctly with the connector on the system board.
6. At a downward angle, insert the free end of the adapter under the tab on the mounting bracket, aligning the holes in the adapter with the posts on the mounting bracket. Rotate the rear of the adapter into the rear mounting bracket, aligning the holes in the adapter with the posts on the rear mounting bracket.

7. Press the Remote Supervisor Adapter II SlimLine firmly into the connector and make sure that all tabs on both mounting brackets secure the adapter in place.
Attention: Incomplete insertion might cause damage to the server or the adapter.
8. If an adapter is installed in expansion slot 1 on the riser-card assembly, remove it.
9. Reinstall the riser-card assembly. Make sure that the riser-card assembly is fully seated in the riser-card connectors on the system board.

See the documentation that comes with the Remote Supervisor Adapter II SlimLine for information about installing the firmware and configuring the adapter. Create a backup copy of the configuration so that if you have to replace the adapter in the future, you can restore the configuration.

If you have other devices to install, do so now. Otherwise, go to “Completing the installation.”

Completing the installation

To complete the installation, complete the following steps:

1. Install the cover. See “Installing the cover” for more information.
2. Install the server in the rack cabinet. See the *Rack Installation Instructions* that come with the server for detailed information about how to install the server in a rack cabinet.

Attention:

- Install the server only in a rack cabinet that has perforated doors.
 - Do not leave open space above or below an installed server in your rack cabinet. To help prevent damage to server components, always install a filler panel to cover the open space and to help ensure proper air circulation. See the documentation that comes with the rack cabinet for more information.
3. Connect the cables and power cords. See “Connecting the cables” on page 19 for more information.
 4. Update the server configuration. See “Updating the server configuration” on page 19 for more information.

Installing the cover

To install the cover, place it into position and slide it forward.

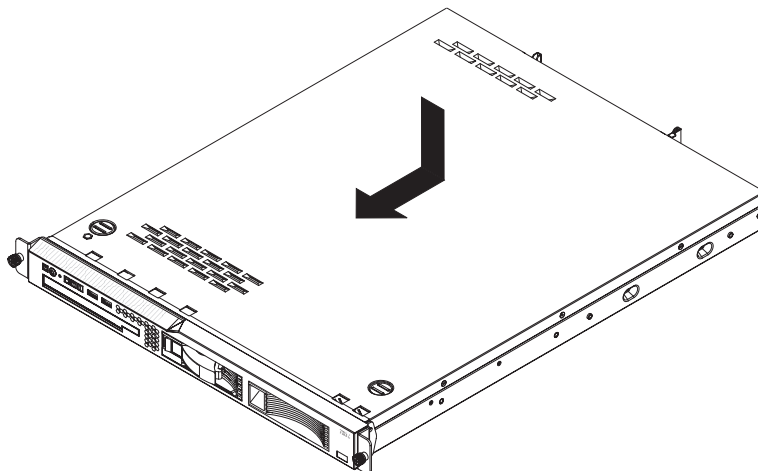

Connecting the cables

The following illustrations show the locations of the input and output connectors on the front and rear of the server.

Front

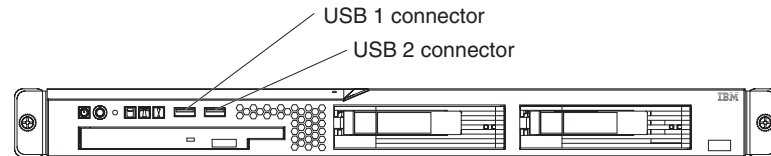

Rear

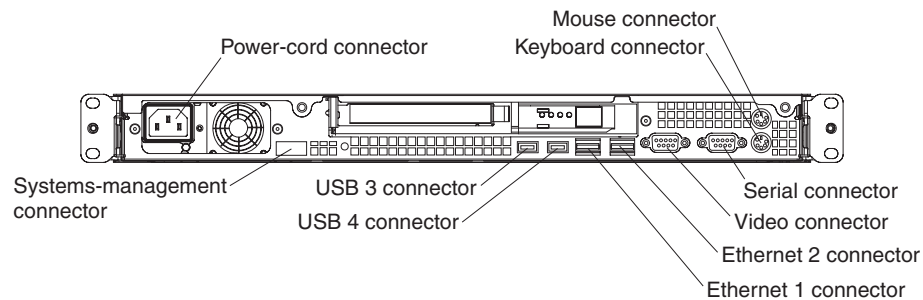

You must turn off the server before you connect or disconnect cables.

See the documentation that comes with any external devices for additional cabling instructions. It might be easier for you to route cables before you connect the devices to the server.

Cable identifiers are printed on the cables that come with the server and devices. Use these identifiers to connect the cables to the correct connectors.

If the server comes with an installed operating system, see the documentation that comes with the operating system for additional cabling instructions.

There is one keyboard connector on the back of the server. Use this connector to connect the server to a keyboard or optional console switch. You can also connect a USB keyboard to the server by using one of the USB connectors. After you install a USB keyboard, you might have to use the Configuration/Setup Utility program to enable keyboardless operation and prevent the POST error message 301 from being displayed during startup. For information about how to connect a USB keyboard to the server, see the documentation that comes with the keyboard. If the server cables and connector panel have color-coded connectors, match the color of each cable end with the color of the connector. For example, match a blue cable end to a blue connector on the panel, a red cable end to a red connector, and so on.

Updating the server configuration

When you start the server for the first time after you add or remove an internal optional device or external SAS device, you might receive a message that the configuration has changed. The Configuration/Setup Utility program starts automatically so that you can save the new configuration settings. For more information, see Chapter 4, “Configuring the server,” on page 25.

Some optional devices have device drivers that you must install. For information about installing device drivers, see the documentation that comes with each device.

If the server has a RAID configuration that uses the SAS/SATA controller with integrated RAID and you have installed or removed a hard disk drive, you might have to reconfigure the disk arrays.

If the server has an optional RAID adapter and you have installed or removed a hard disk drive, see the documentation that comes with the RAID adapter for information about reconfiguring the disk arrays.

For information about configuring the integrated Gigabit Ethernet controllers, see the *User's Guide*.

Chapter 3. Server controls, LEDs, and power

This chapter describes the controls and light-emitting diodes (LEDs) and how to turn the server on and off.

Front view

The following illustration shows the controls, light-emitting diodes (LEDs), and connectors on the front of the server.

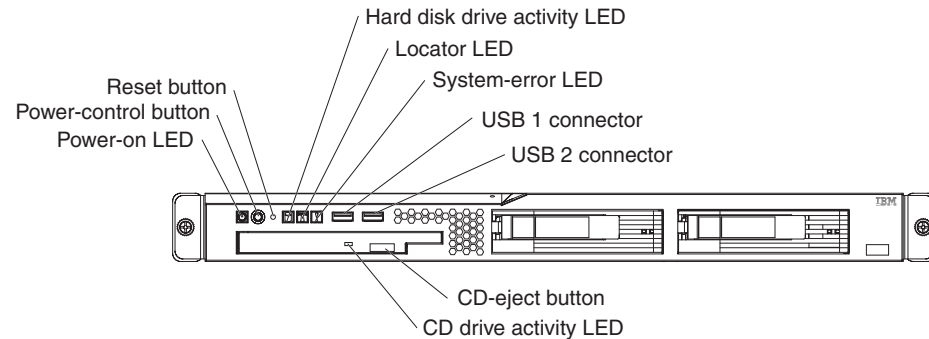

Power-on LED: When this LED is lit and not flashing, it indicates that the server is turned on. When this LED is flashing, it indicates that the server is turned off and still connected to an ac power source. When this LED is off, it indicates that ac power is not present, or the power supply or the LED itself has failed.

Note: If this LED is off, it does not mean that there is no electrical power in the server. The LED might be burned out. To remove all electrical power from the server, you must disconnect the power cord from the electrical outlet.

Power-control button: Press this button to turn the server on and off manually. A power-control-button shield comes installed around the button to prevent the server from being turned off accidentally. You can remove this disk-shaped shield if you prefer.

Reset button: Press this button to reset the server and run the power-on self-test (POST). You might have to use a pen or the end of a straightened paper clip to press the button.

Hard disk drive activity LED: When this LED is flashing, it indicates that a hard disk drive is in use.

Locator LED: This LED can be lit remotely by the system administrator to aid in visually locating the server. You can use IBM Director to light this LED remotely.

System-error LED: When this LED is lit, it indicates that a system error has occurred. An LED on the system board might also be lit to help isolate the error. See Chapter 5, "Solving problems," on page 29 for additional information.

USB connectors: Connect a USB device to either of these connectors.

CD-eject button: Press this button to release a CD from the CD drive.

CD drive activity LED: When this LED is lit, it indicates that the CD drive is in use.

Rear view

The following illustration shows the LEDs on the rear of the server.

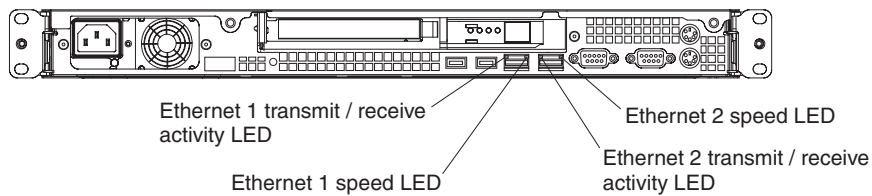

Ethernet transmit/receive activity LED: This LED is on each Ethernet connector. When this LED is lit, it indicates that there is activity between the server and the network.

Ethernet speed LED: This LED is on each Ethernet connector. When this LED is lit, it indicates that the Ethernet network speed is 1 Gbps. When this LED is off, it indicates that the Ethernet network speed is 10 Mbps or 100 Mbps.

The following illustration shows the connectors on the rear of the server.

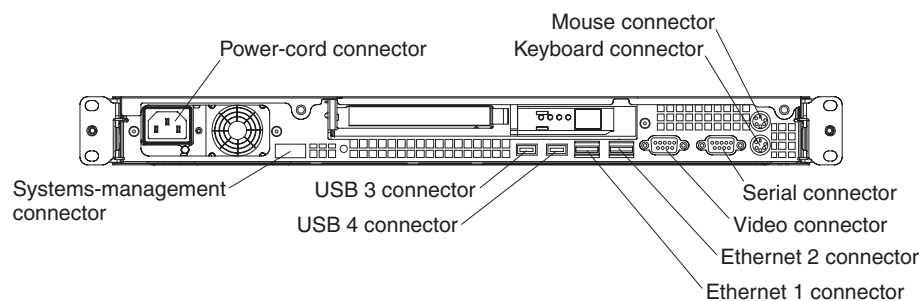

Power-cord connector: Connect the power cord to this connector.

Keyboard connector: Connect a PS/2 keyboard to this connector.

Mouse connector: Connect a mouse or other PS/2 device to this connector.

Serial connector: Connect a 9-pin serial device to this connector.

Video connector: Connect a monitor to this connector.

Ethernet connector: Use either of these connectors to connect the server to a network.

USB connector: Connect a USB device to either of these connectors.

Systems-management connector: Connect the server to a network for systems-management information control. This connector is active only if you have installed a Remote Supervisor Adapter II SlimLine, and it is used only by the Remote Supervisor Adapter II SlimLine.

Server power features

When the server is connected to an ac power source but is not turned on, the operating system does not run, and all core logic except for the service processor is shut down; however, the server can respond to requests from the service processor (the baseboard management controller), such as a remote request to turn on the server.

Turning on the server

Approximately 20 seconds after the server is connected to ac power, the power-control button becomes active, and one or more fans might start running to provide cooling while the server is connected to power. You can turn on the server and start the operating system by pressing the power-control button.

The server can also be turned on in any of the following ways:

- If a power failure occurs while the server is turned on, the server will restart automatically when power is restored.
- If your operating system supports the systems-management software for an optional Remote Supervisor Adapter II SlimLine, the systems-management software can turn on the server.
- If your operating system supports the Wake on LAN feature, the Wake on LAN feature can turn on the server.

Note: When 4 GB or more of memory (physical or logical) is installed, some memory is reserved for various system resources and is unavailable to the operating system. The amount of memory that is reserved for system resources depends on the operating system, the configuration of the server, and the configured PCI optional devices.

Turning off the server

When you turn off the server and leave it connected to ac power, the server can respond to requests from the service processor, such as a remote request to turn on the server. While the server remains connected to ac power, one or more fans might continue to run. To remove all power from the server, you must disconnect it from the power source.

Some operating systems require an orderly shutdown before you turn off the server. See your operating-system documentation for information about shutting down the operating system.

Statement 5:



CAUTION:

The power control button on the device and the power switch on the power supply do not turn off the electrical current supplied to the device. The device also might have more than one power cord. To remove all electrical current from the device, ensure that all power cords are disconnected from the power source.



The server can be turned off in any of the following ways:

- You can turn off the server from the operating system, if your operating system supports this feature. After an orderly shutdown of the operating system, the server will be turned off automatically.
- You can press the power-control button to start an orderly shutdown of the operating system and turn off the server, if your operating system supports this feature.
- If the operating system stops functioning, you can press and hold the power-control button for more than 4 seconds to turn off the server.
- If an optional Remote Supervisor Adapter II SlimLine is installed in the server, the server can be turned off from the Remote Supervisor Adapter II SlimLine user interface.
- The integrated systems-management processor (mini-BMC) can turn off the server as an automatic response to a critical system failure.
- You can turn off the server through a request from the service processor.

Chapter 4. Configuring the server

The *ServerGuide Setup and Installation* CD provides software setup tools and installation tools that are specifically designed for your IBM server. Use this CD during the initial installation of the server to configure basic hardware features and to simplify the operating-system installation. (See “Using the ServerGuide Setup and Installation CD” for more information.)

In addition to the *ServerGuide Setup and Installation* CD, you can use the following configuration programs to customize the server hardware:

- Configuration/Setup Utility program
- LSI Logic Configuration Utility program
- Baseboard management controller SMBridge management utility program

The following table lists the different server configurations and the applications available for configuring and managing RAID arrays.

Table 3.

Server Configuration	RAID array configuration (before operating system is installed)	RAID array management (after operating system is installed)
Integrated SATA and no SAS controller card installed	None	None
SAS/SATA controller card (LSI 1064) installed	LSI Utility (BIOS Utility CTRL-C), ServerGuide	MyStorage (for monitoring storage only)
ServeRAID 8s adapter installed	ServeRAID Manager Hardware Boot CD, BIOS Utility (CTRL-A), ServerGuide	ServeRAID Manager, ARCCONF (CLI)

For more information about these programs, see “Configuring the server” in the *User’s Guide* on the *IBM System x Documentation* CD.

Using the ServerGuide Setup and Installation CD

The *ServerGuide Setup and Installation* CD provides programs to detect the server model and installed optional hardware devices, configure the server hardware, provide device drivers, and help you install the operating system. For information about the supported operating-system versions, see the label on the CD. If the *ServerGuide Setup and Installation* CD did not come with the server, you can download the latest version from <http://www.ibm.com/pc/qtechinfo/MIGR-4ZKPPT.html>.

To start the *ServerGuide Setup and Installation* CD, complete the following steps:

1. Insert the CD, and restart the server. If the CD does not start, see “ServerGuide problems” on page 46.
2. Follow the instructions on the screen to:
 - a. Select your language.
 - b. Select your keyboard layout and country.
 - c. View the overview to learn about ServerGuide features.
 - d. View the readme file to review installation tips about your operating system and adapter.

- e. Start the setup and hardware configuration programs.
- f. Start the operating-system installation. You will need your operating-system CD.

Using the Configuration/Setup Utility program

The Configuration/Setup Utility program is part of the BIOS. You can use it to perform the following tasks:

- View configuration information
- View and change assignments for devices and I/O ports
- Set the date and time
- Set and change passwords
- Set and change the startup characteristics of the server and the order of startup devices (startup-drive sequence)
- Set and change settings for advanced hardware features
- View and clear the error log
- Change interrupt request (IRQ) settings
- Enable USB keyboard and mouse support
- Resolve configuration conflicts

To start the Configuration/Setup Utility program, complete the following steps:

1. Turn on the server.
2. When the message Press F1 for Configuration/Setup is displayed, press F1. If an administrator password has been set, you must type the administrator password to access the full Configuration/Setup Utility menu.
3. Follow the instructions on the screen.

See the *User's Guide* that is on the *IBM System x Documentation CD* for more information about using the Configuration/Setup Utility program.

Using the LSI Logic Configuration Utility program

Use the LSI Logic Configuration Utility program to configure hot-swap hard disk drives that are connected to the SAS/SATA controller.

Important: If the server is a simple-swap SATA model and you have installed an optional SATA RAID Kit, you can use the LSI Logic Configuration Utility program to configure the simple-swap SATA hard disk drives.

- If the server is a simple-swap SATA model and you have installed an optional SATA RAID Kit, you can use the LSI Logic Configuration Utility program to configure the simple-swap SATA hard disk drives.
- If you install an optional RAID controller in the server, such as the ServeRAID 8s controller, use the configuration software that comes with the adapter to configure the hard disk drives.

To start the LSI Logic Configuration Utility program, complete the following steps:

1. Turn on the server.
2. When the prompt Press CTRL-C to start LSI Logic Configuration Utility... appears, press Ctrl+C. If you have set an administrator password, you are prompted to type the password.

3. Use the arrow keys to select the adapter (SAS controller) for which you want to change settings. Use the Help function to see instructions and available actions for this screen. If you select SAS Topology or Advanced Adapter Properties, additional screens are displayed.
4. To change the settings of the selected items, follow the instructions on the screen.
5. Press Enter to save your changes.

Using the baseboard management controller

The baseboard management controller provides basic environmental monitoring functions for the server. If an environmental condition exceeds a threshold or if a system component fails, the baseboard management controller lights LEDs to help you diagnose the problem and also records the error in the BMC system event log.

The baseboard management controller also provides command-line interface remote server management capabilities through the Avocent SMBridge management utility program. The command-line interface provides direct access to server management functions through the Intelligent Platform Management Interface (IPMI) protocol. Use the command-line interface to issue commands to control the server power, view system information, and identify the server. You can also save one or more commands as a text file and run the file as a script.

Chapter 5. Solving problems

This chapter provides basic troubleshooting information to help you solve some common problems that might occur while you are setting up the server.

If you cannot locate and correct a problem by using the information in this chapter, see Appendix A, “Getting help and technical assistance,” on page 49, the *Problem Determination and Service Guide* on the IBM System x Documentation CD, and the “Server Support” flowchart in the front of this document.

Diagnostic tools overview

The following tools are available to help you diagnose and solve hardware-related problems:

- **POST beep codes**

The power-on self-test beep codes indicate the detection of a problem.

- One beep indicates successful completion of POST, with no errors.
- More than one beep indicates that POST detected a problem. Error messages also appear during startup if POST detects a hardware-configuration problem. See “POST beep codes” and the *Problem Determination and Service Guide* on the IBM System x Documentation CD for more information.

- **Troubleshooting charts**

These charts list problem symptoms and steps to correct the problems. See “Troubleshooting tables” on page 37 for more information.

- **Diagnostic programs and error messages**

The system diagnostic programs are provided on the *IBM Enhanced Diagnostics* CD. These programs test the major components of the server. See the *Problem Determination and Service Guide* on the IBM System x Documentation CD for more information.

POST beep codes

POST emits one beep to signal successful completion. If POST detects a problem during startup, other beep codes might occur. Use the following beep code descriptions to help diagnose and solve problems that are detected during startup.

Note: See the *Problem Determination and Service Guide* on the IBM System x Documentation CD for more information about the POST beep codes.

One beep

POST was completed successfully without detecting any errors.

Other beep codes

See the *Problem Determination and Service Guide* on the IBM System x Documentation CD for information about other beep codes.

POST error codes

The following table provides an abbreviated list of the error codes that might appear during POST. See the *Problem Determination and Service Guide* on the IBM *System x Documentation* CD for more information about the POST error codes. To check for updated technical information, go to <http://www.ibm.com/servers/eserver/support/xseries/index.html>, select **System x3250**, and click **Go**; then, click the **Install and use** tab and click **Product documentation**.

Table 4. Abbreviated list of POST error codes

Error code	Description	Action
062	Three consecutive boot failures using the default configuration.	<ol style="list-style-type: none">Flash the system firmware to the latest level (see the <i>Problem Determination and Service Guide</i> on the IBM <i>System x Documentation</i> CD).(Trained service technician only) Replace the system board.
101	Tick timer internal interrupt failure.	(Trained service technician only) Replace the system board.
102	Internal timer channel 2 test failure.	(Trained service technician only) Replace the system board.
151	Real-time clock error.	<ol style="list-style-type: none">Reseat the battery.Replace the following components one at a time, in the order shown, restarting the server each time:<ol style="list-style-type: none">Battery(Trained service technician only) System board
161	The real-time clock battery has failed.	<ol style="list-style-type: none">Reseat the battery.Replace the following components one at a time, in the order shown, restarting the server each time:<ol style="list-style-type: none">Battery(Trained service technician only) System board

Table 4. Abbreviated list of POST error codes (continued)

<ul style="list-style-type: none"> • Follow the suggested actions in the order in which they are listed in the Action column until the problem is solved. • See the parts listing in the <i>Problem Determination and Service Guide</i> to determine which components are customer replaceable units (CRU) and which components are field replaceable units (FRU). • If an action step is preceded by “(Trained service technician only),” that step must be performed only by a trained service technician. 		
Error code	Description	Action
162	Invalid configuration information or CMOS random-access memory (RAM) checksum failure.	<ol style="list-style-type: none"> 1. Run the Configuration/Setup Utility program, select Load Default Settings, and save the settings. 2. Reseat the battery. 3. Replace the battery. 4. (Trained service technician only) Replace the system board.
163	The time of day has not been set.	Run the Configuration/Setup Utility program, set the date and time, and save the settings.
164	Memory size has changed.	<ol style="list-style-type: none"> 1. Run the Configuration/Setup Utility program; then, exit, saving the configuration settings. 2. Reseat the DIMMs.
184	Power-on password damaged.	<ol style="list-style-type: none"> 1. Run the Configuration/Setup Utility program, select Load Default Settings, and save the settings. 2. Reseat the battery. 3. Replace the following components one at a time, in the order shown, restarting the server each time: <ol style="list-style-type: none"> a. Battery b. (Trained service technician only) System board
187	VPD serial number not set.	<ol style="list-style-type: none"> 1. Reseat the optional Remote Supervisor Adapter II SlimLine. 2. (Trained service technician only) Replace the system board.
189	Three attempts were made to access the server with an incorrect password.	Restart the server and enter the administrator password; then, run the Configuration/Setup Utility program and change the power-on password.

Table 4. Abbreviated list of POST error codes (continued)

<ul style="list-style-type: none"> • Follow the suggested actions in the order in which they are listed in the Action column until the problem is solved. • See the parts listing in the <i>Problem Determination and Service Guide</i> to determine which components are customer replaceable units (CRU) and which components are field replaceable units (FRU). • If an action step is preceded by “(Trained service technician only),” that step must be performed only by a trained service technician. 		
Error code	Description	Action
289	A failing DIMM was disabled.	<ol style="list-style-type: none"> 1. Make sure that the DIMM is installed correctly (see “Installing a memory module” on page 9). 2. Reseat the DIMM. 3. Replace the DIMM.
301	Keyboard and keyboard controller error.	<ol style="list-style-type: none"> 1. If you have installed a USB keyboard, run the Configuration/Setup Utility program and enable keyboardless operation to prevent the POST error message 301 from being displayed during startup. 2. Reseat the keyboard cable in the connector. 3. Replace the following components one at a time, in the order shown, restarting the server each time: <ol style="list-style-type: none"> a. Keyboard b. (Trained service technician only) System board
303	Keyboard controller error.	<ol style="list-style-type: none"> 1. Reseat the keyboard cable in the connector. 2. Replace the following components one at a time, in the order shown, restarting the server each time: <ol style="list-style-type: none"> a. Keyboard b. (Trained service technician only) System board
1162	Serial port error.	<ol style="list-style-type: none"> 1. Run the Configuration/Setup Utility program and make sure that the serial port settings are correct. 2. (Trained service technician only) Replace the system board.

Table 4. Abbreviated list of POST error codes (continued)

<ul style="list-style-type: none"> • Follow the suggested actions in the order in which they are listed in the Action column until the problem is solved. • See the parts listing in the <i>Problem Determination and Service Guide</i> to determine which components are customer replaceable units (CRU) and which components are field replaceable units (FRU). • If an action step is preceded by “(Trained service technician only),” that step must be performed only by a trained service technician. 		
Error code	Description	Action
178x	Fixed disk error. Note: x is the drive that has the error.	<ol style="list-style-type: none"> 1. Run the hard disk drive diagnostic tests on drive x (see “Running the diagnostic programs” in the <i>Problem Determination and Service Guide</i> on the IBM System x Documentation CD). 2. Reseat the following components, depending on the server model: <ul style="list-style-type: none"> • Hot-swap models: Hard disk drive x • Simple-swap models: <ol style="list-style-type: none"> a. Hard disk drive x b. Hard disk drive x cable 3. Replace the following components one at a time, depending on the server model, in the order shown, restarting the server each time: <ul style="list-style-type: none"> • Hot-swap models: <ol style="list-style-type: none"> a. Hard disk drive x b. Hard disk drive backplane c. (Trained service technician only) System board • Simple-swap models: <ol style="list-style-type: none"> a. Hard disk drive x b. Hard disk drive x cable c. (Trained service technician only) System board
180x	A PCI adapter requested a resource that is not available.	Run the Configuration/Setup Utility program and make sure that the resources that are needed by the PCI adapter are available.

Table 4. Abbreviated list of POST error codes (continued)

<ul style="list-style-type: none"> • Follow the suggested actions in the order in which they are listed in the Action column until the problem is solved. • See the parts listing in the <i>Problem Determination and Service Guide</i> to determine which components are customer replaceable units (CRU) and which components are field replaceable units (FRU). • If an action step is preceded by “(Trained service technician only),” that step must be performed only by a trained service technician. 		
Error code	Description	Action
5962	IDE DVD drive configuration error.	<ol style="list-style-type: none"> 1. Run the Configuration/Setup Utility program and load the default settings (see “Using the Configuration/Setup Utility program” on page 26). 2. Reseat the following components: <ol style="list-style-type: none"> a. DVD drive cable b. DVD drive 3. Replace the following components one at a time, in the order shown, restarting the server each time: <ol style="list-style-type: none"> a. DVD drive cable b. DVD drive c. (Trained service technician only) System board
8603	Pointing-device error.	<ol style="list-style-type: none"> 1. Reseat the pointing device. 2. Replace the following components one at a time, in the order shown, restarting the server each time: <ol style="list-style-type: none"> a. Pointing device b. (Trained service technician only) System board
00012000	Processor machine check error.	<ol style="list-style-type: none"> 1. (Trained service technician only) Reseat the microprocessor. 2. Replace the following components one at a time, in the order shown, restarting the server each time: <ol style="list-style-type: none"> a. (Trained service technician only) Microprocessor b. (Trained service technician only) System board
00019xxx	Microprocessor x is not functioning or failed the built-in self-test.	Make sure that microprocessor x is installed correctly. If the problem remains, call for service.

Table 4. Abbreviated list of POST error codes (continued)

<ul style="list-style-type: none"> • Follow the suggested actions in the order in which they are listed in the Action column until the problem is solved. • See the parts listing in the <i>Problem Determination and Service Guide</i> to determine which components are customer replaceable units (CRU) and which components are field replaceable units (FRU). • If an action step is preceded by “(Trained service technician only),” that step must be performed only by a trained service technician. 		
Error code	Description	Action
01298001	No update data for microprocessor 1.	<ol style="list-style-type: none"> 1. Update the BIOS code again (see the <i>Problem Determination and Service Guide</i> on the IBM System x Documentation CD). 2. (Trained service technician only) Reseat the microprocessor. 3. (Trained service technician only) Replace the microprocessor.
01298101	Bad update data for microprocessor 1.	<ol style="list-style-type: none"> 1. Update the BIOS code again (see the <i>Problem Determination and Service Guide</i> on the IBM System x Documentation CD). 2. (Trained service technician only) Reseat the microprocessor. 3. (Trained service technician only) Replace the microprocessor.

Table 4. Abbreviated list of POST error codes (continued)

Error code	Description	Action
I9990301	Hard disk drive boot sector error.	<ul style="list-style-type: none"> 1. Reseat the following components, depending on the server model: <ul style="list-style-type: none"> • Hot-swap models: <ul style="list-style-type: none"> a. Hard disk drive b. SAS/SATA controller • Simple-swap models: <ul style="list-style-type: none"> a. Hard disk drive b. Hard disk drive cable 2. Replace the following components one at a time, depending on the server model, in the order shown, restarting the server each time: <ul style="list-style-type: none"> • Hot-swap models: <ul style="list-style-type: none"> a. Hard disk drive b. Hard disk drive backplane c. SAS/SATA controller d. (Trained service technician only) System board • Simple-swap models: <ul style="list-style-type: none"> a. Hard disk drive b. Hard disk drive cable c. (Trained service technician only) System board

Troubleshooting tables

Use the troubleshooting tables to find solutions to problems that have identifiable symptoms. See the *Problem Determination and Service Guide* on the IBM System x Documentation CD for more detailed troubleshooting information. If you cannot find a problem in these tables, run the diagnostic programs (see “Running the diagnostic programs” in the *Problem Determination and Service Guide*).

If you have just added new software or a new optional device and the server is not working, complete the following steps before you use the troubleshooting tables:

1. Check the system-error LED on the operator information panel (see Chapter 3, “Server controls, LEDs, and power,” on page 21).
2. Remove the software or device that you just added.
3. Run the diagnostic tests to determine whether the server is running correctly.
4. Reinstall the new software or new device.

CD or DVD drive problems

<ul style="list-style-type: none"> • Follow the suggested actions in the order in which they are listed in the Action column until the problem is solved. • See the parts listing in the <i>Problem Determination and Service Guide</i> to determine which components are customer replaceable units (CRU) and which components are field replaceable units (FRU). • If an action step is preceded by “(Trained service technician only),” that step must be performed only by a trained service technician. 	
Symptom	Action
The CD or DVD drive is not recognized.	<ol style="list-style-type: none"> 1. Make sure that: <ul style="list-style-type: none"> • The IDE channel to which the CD or DVD drive is attached (primary) is enabled in the Configuration/Setup Utility program. • All cables and jumpers are installed correctly. • The correct device driver is installed for the CD or DVD drive. 2. Run the CD, CD-RW, or DVD drive diagnostic programs. 3. Reseat the following components: <ol style="list-style-type: none"> a. CD or DVD drive b. CD or DVD interface board cable 4. Replace the following components one at a time, in the order shown, restarting the server each time: <ol style="list-style-type: none"> a. CD or DVD drive b. CD or DVD drive interface board cable c. CD or DVD interface board d. (Trained service technician only) System board
A CD or DVD is not working correctly.	<ol style="list-style-type: none"> 1. Clean the CD or DVD. 2. Run the CD or DVD drive diagnostic programs. 3. Reseat the CD or DVD drive. 4. Replace the CD or DVD drive.
The CD or DVD drive tray is not working.	<ol style="list-style-type: none"> 1. Make sure that the server is turned on. 2. Insert the end of a straightened paper clip into the manual tray-release opening. 3. Reseat the CD or DVD drive. 4. Replace the CD or DVD drive.

General problems

<ul style="list-style-type: none"> • Follow the suggested actions in the order in which they are listed in the Action column until the problem is solved. • See the parts listing in the <i>Problem Determination and Service Guide</i> to determine which components are customer replaceable units (CRU) and which components are field replaceable units (FRU). • If an action step is preceded by “(Trained service technician only),” that step must be performed only by a trained service technician. 	
Symptom	Action
A cover lock is broken, an LED is not working, or a similar problem has occurred.	If the part is a CRU, replace it. If the part is a FRU, the part must be replaced by a trained service technician.

Hard disk drive problems

<ul style="list-style-type: none"> • Follow the suggested actions in the order in which they are listed in the Action column until the problem is solved. • See the parts listing in the <i>Problem Determination and Service Guide</i> to determine which components are customer replaceable units (CRU) and which components are field replaceable units (FRU). • If an action step is preceded by “(Trained service technician only),” that step must be performed only by a trained service technician. 	
Symptom	Action
Not all drives are recognized by the hard disk drive diagnostic test (the Fixed Disk test).	Remove the drive indicated on the diagnostic tests; then, run the hard disk drive diagnostic test again. If the remaining drives are recognized, replace the drive that you removed with a new one.
The server stops responding during the hard disk drive diagnostic test.	Remove the hard disk drive that was being tested when the server stopped responding, and run the diagnostic test again. If the hard disk drive diagnostic test runs successfully, replace the drive that you removed with a new one.
A hard disk drive was not detected while the operating system was being started.	Reseat all hard disk drives and cables; then, run the hard disk drive diagnostic tests again.
A hard disk drive passes the diagnostic Fixed Disk Test but the problem remains.	Run the diagnostic SCSI Attached Disk Test. Note: Use the SCSI Attached Disk test for drives that are part of RAID arrays. Use the Fixed Disk Test for SATA drives that are not part of RAID arrays.

Intermittent problems

<ul style="list-style-type: none"> Follow the suggested actions in the order in which they are listed in the Action column until the problem is solved. See the parts listing in the <i>Problem Determination and Service Guide</i> to determine which components are customer replaceable units (CRU) and which components are field replaceable units (FRU). If an action step is preceded by “(Trained service technician only),” that step must be performed only by a trained service technician. 	
Symptom	Action
A problem occurs only occasionally and is difficult to diagnose.	<ol style="list-style-type: none"> Make sure that: <ul style="list-style-type: none"> All cables and cords are connected securely to the rear of the server and attached devices. When the server is turned on, air is flowing from the fan grille. If there is no airflow, the fan is not working. This can cause the server to overheat and shut down. Check the system-error logs (see “Using the Configuration/Setup Utility program” on page 26). <p>If the problem remains, call for service.</p>

Keyboard, mouse, or pointing-device problems

<ul style="list-style-type: none"> Follow the suggested actions in the order in which they are listed in the Action column until the problem is solved. See the parts listing in the <i>Problem Determination and Service Guide</i> to determine which components are customer replaceable units (CRU) and which components are field replaceable units (FRU). If an action step is preceded by “(Trained service technician only),” that step must be performed only by a trained service technician. 	
Symptom	Action
All or some keys on the keyboard do not work.	<ol style="list-style-type: none"> If the server is attached to a KVM switch, bypass the KVM switch to eliminate it as a possible cause of the problem: connect the keyboard cable directly to the correct connector on the rear of the server. If you have installed a USB keyboard, run the Configuration/Setup Utility program and enable keyboardless operation to prevent the POST error message 301 from being displayed during startup. If you are using a USB hub, disconnect the USB device from the hub and connect it directly to the server. Make sure that: <ul style="list-style-type: none"> The keyboard cable is securely connected to the server and the keyboard and mouse cables are not reversed. The server and the monitor are turned on. Reseat the keyboard cable. Replace the following components one at a time, in the order shown, restarting the server each time: <ol style="list-style-type: none"> Keyboard (Trained service technician only) System board

<ul style="list-style-type: none"> • Follow the suggested actions in the order in which they are listed in the Action column until the problem is solved. • See the parts listing in the <i>Problem Determination and Service Guide</i> to determine which components are customer replaceable units (CRU) and which components are field replaceable units (FRU). • If an action step is preceded by “(Trained service technician only),” that step must be performed only by a trained service technician. 	
Symptom	Action
The mouse or pointing device does not work.	<ol style="list-style-type: none"> 1. If the server is attached to a KVM switch, bypass the KVM switch to eliminate it as a possible cause of the problem: connect the mouse or pointing-device cable directly to the correct connector on the rear of the server. 2. Make sure that: <ul style="list-style-type: none"> • The mouse or pointing-device cable is securely connected and the keyboard and mouse cables are not reversed. • The mouse device drivers are installed correctly. • The mouse is enabled in the Configuration/Setup Utility program. 3. Reseat the mouse or pointing device cable. 4. Replace the following components one at a time, in the order shown, restarting the server each time: <ol style="list-style-type: none"> a. Mouse or pointing device b. (Trained service technician only) System board

Memory problems

<ul style="list-style-type: none"> • Follow the suggested actions in the order in which they are listed in the Action column until the problem is solved. • See the parts listing in the <i>Problem Determination and Service Guide</i> to determine which components are customer replaceable units (CRU) and which components are field replaceable units (FRU). • If an action step is preceded by “(Trained service technician only),” that step must be performed only by a trained service technician. 	
Symptom	Action
The amount of system memory that is displayed is less than the amount of installed physical memory.	<ol style="list-style-type: none"> 1. Make sure that: <ul style="list-style-type: none"> • No error LEDs are lit on the operator information panel. • The memory modules are seated correctly. • You have installed the correct type of memory (see “Installing a memory module” on page 9). • All banks of memory are enabled. The server might have automatically disabled a memory bank when it detected a problem. 2. Check the POST error log for error message 289 (see “Using the Configuration/Setup Utility program” on page 26); if a DIMM was disabled by a system-management interrupt (SMI), replace the DIMM. 3. Run memory diagnostics (see “Running the diagnostic programs” in the <i>Problem Determination and Service Guide</i>). 4. Add one pair of DIMMs at a time, making sure that the DIMMs in each pair match. 5. Reseat the DIMMs. 6. Replace the following components one at a time, in the order shown, restarting the server each time: <ol style="list-style-type: none"> a. DIMMs b. (Trained service technician only) System board

Microprocessor problems

<ul style="list-style-type: none"> • Follow the suggested actions in the order in which they are listed in the Action column until the problem is solved. • See the parts listing in the <i>Problem Determination and Service Guide</i> to determine which components are customer replaceable units (CRU) and which components are field replaceable units (FRU). • If an action step is preceded by “(Trained service technician only),” that step must be performed only by a trained service technician. 	
Symptom	Action
The server emits a continuous beep during POST, indicating that the microprocessor is not working correctly.	<ol style="list-style-type: none"> 1. Correct any errors that are indicated by the LEDs (see “System-board LEDs” in the <i>Problem Determination and Service Guide</i>). 2. Make sure that the server supports the microprocessor. 3. (Trained service technician only) Make sure that the microprocessor is seated correctly. 4. (Trained service technician only) Replace the microprocessor.

Monitor problems

Some IBM monitors have their own self-tests. If you suspect a problem with your monitor, see the documentation that comes with the monitor for instructions for testing and adjusting the monitor.

<ul style="list-style-type: none"> • Follow the suggested actions in the order in which they are listed in the Action column until the problem is solved. • See the parts listing in the <i>Problem Determination and Service Guide</i> to determine which components are customer replaceable units (CRU) and which components are field replaceable units (FRU). • If an action step is preceded by “(Trained service technician only),” that step must be performed only by a trained service technician. 	
Symptom	Action
Testing the monitor	<ol style="list-style-type: none"> 1. Make sure that the monitor cables are firmly connected. 2. Try using a different monitor on the server, or try testing the monitor on a different server. 3. Run the diagnostic programs (see the <i>Problem Determination and Service Guide</i>). If the monitor passes the diagnostic programs, the problem might be a video device driver. 4. (Trained service technician only) Replace the system board.

- Follow the suggested actions in the order in which they are listed in the Action column until the problem is solved.
- See the parts listing in the *Problem Determination and Service Guide* to determine which components are customer replaceable units (CRU) and which components are field replaceable units (FRU).
- If an action step is preceded by “(Trained service technician only),” that step must be performed only by a trained service technician.

Symptom	Action
The screen is blank.	<ol style="list-style-type: none"> 1. If the server is attached to a KVM switch, bypass the KVM switch to eliminate it as a possible cause of the problem: connect the monitor cable directly to the correct connector on the rear of the server. 2. Make sure that: <ul style="list-style-type: none"> • The server is turned on. If there is no power to the server, see “Power problems” on page 45. • The monitor cables are connected correctly. • The monitor is turned on and the brightness and contrast controls are adjusted correctly. • No beep codes sound when the server is turned on. <p>Important: In some memory configurations, the 3-3-3 beep code might sound during POST, followed by a blank monitor screen. If this occurs and the Boot Fail Count option in the Start Options of the Configuration/Setup Utility program is enabled, you must restart the server three times to reset the configuration settings to the default configuration (the memory connector or bank of connectors enabled).</p> 3. Make sure that the correct server is controlling the monitor, if applicable. 4. Make sure that damaged BIOS code is not affecting the video; see “Recovering from BIOS update failure” in the <i>Problem Determination and Service Guide</i>. 5. See “Solving undetermined problems” in the <i>Problem Determination and Service Guide</i>.
The monitor works when you turn on the server, but the screen goes blank when you start some application programs.	<ol style="list-style-type: none"> 1. Make sure that: <ul style="list-style-type: none"> • The application program is not setting a display mode that is higher than the capability of the monitor. • You installed the necessary device drivers for the application. 2. Run video diagnostics (see the <i>Problem Determination and Service Guide</i>). <ul style="list-style-type: none"> • If the server passes the video diagnostics, the video is good; see “Solving undetermined problems” in the <i>Problem Determination and Service Guide</i>. • (Trained service technician only) If the server fails the video diagnostics, replace the system board.

- Follow the suggested actions in the order in which they are listed in the Action column until the problem is solved.
- See the parts listing in the *Problem Determination and Service Guide* to determine which components are customer replaceable units (CRU) and which components are field replaceable units (FRU).
- If an action step is preceded by “(Trained service technician only),” that step must be performed only by a trained service technician.

Symptom	Action
<p>The monitor has screen jitter, or the screen image is wavy, unreadable, rolling, or distorted.</p>	<ol style="list-style-type: none"> 1. If the monitor self-tests show that the monitor is working correctly, consider the location of the monitor. Magnetic fields around other devices (such as transformers, appliances, fluorescent lights, and other monitors) can cause screen jitter or wavy, unreadable, rolling, or distorted screen images. If this happens, turn off the monitor. Attention: Moving a color monitor while it is turned on might cause screen discoloration. Move the device and the monitor at least 305 mm (12 in.) apart, and turn on the monitor. Notes: <ol style="list-style-type: none"> a. To prevent diskette drive read/write errors, make sure that the distance between the monitor and any external diskette drive is at least 76 mm (3 in.). b. Non-IBM monitor cables might cause unpredictable problems. 2. Reseat the following components: <ul style="list-style-type: none"> • Monitor cable • Remote Supervisor Adapter II SlimLine (if one is installed) 3. Replace the following components one at a time, in the order shown, restarting the server each time: <ol style="list-style-type: none"> a. Monitor cable b. Monitor c. Remote Supervisor Adapter II SlimLine (if one is installed) d. (Trained service technician only) System board
<p>Wrong characters appear on the screen.</p>	<ol style="list-style-type: none"> 1. If the wrong language is displayed, update the BIOS code with the correct language. 2. Reseat the monitor cable. 3. Replace the following components one at a time, in the order shown, restarting the server each time: <ol style="list-style-type: none"> a. Monitor b. (Trained service technician only) System board

Optional-device problems

<ul style="list-style-type: none"> • Follow the suggested actions in the order in which they are listed in the Action column until the problem is solved. • See the parts listing in the <i>Problem Determination and Service Guide</i> to determine which components are customer replaceable units (CRU) and which components are field replaceable units (FRU). • If an action step is preceded by “(Trained service technician only),” that step must be performed only by a trained service technician. 	
Symptom	Action
An IBM optional device that was just installed does not work.	<ol style="list-style-type: none"> 1. Make sure that: <ul style="list-style-type: none"> • The device is designed for the server (see http://www.ibm.com/servers/eserver/serverproven/compat/us/). • You followed the installation instructions that came with the device and the device is installed correctly. • You have not loosened any other installed devices or cables. • You updated the configuration information in the Configuration/Setup Utility program. Whenever a device is changed, you must update the configuration. 2. Reseat the device that you just installed. 3. Replace the device that you just installed.
An IBM optional device that used to work does not work now.	<ol style="list-style-type: none"> 1. Make sure that all of the cable connections for the device are secure. 2. If the device comes with test instructions, use those instructions to test the device. 3. Reseat the failing device. 4. Replace the failing device.

Power problems

<ul style="list-style-type: none"> • Follow the suggested actions in the order in which they are listed in the Action column until the problem is solved. • See the parts listing in the <i>Problem Determination and Service Guide</i> to determine which components are customer replaceable units (CRU) and which components are field replaceable units (FRU). • If an action step is preceded by “(Trained service technician only),” that step must be performed only by a trained service technician. 	
Symptom	Action
<p>The power-control button does not work, and the reset button does work (the server does not start).</p> <p>Note: The power-control button will not function until 20 seconds after the server has been connected to ac power.</p>	<ol style="list-style-type: none"> 1. Make sure that the power-control button is working correctly: <ol style="list-style-type: none"> a. Disconnect the server power cords. b. Reconnect the power cords. c. Press the power-control button. d. If the server does not start, disconnect the server power cords and reseal the operator information panel cables; then, repeat steps 1b through 1c. If the problem remains, replace the operator information panel. 2. Make sure that: <ul style="list-style-type: none"> • The ac power cord is correctly connected to the server and to a working electrical outlet. • The server contains the correct type of DIMMs. • The DIMMs are correctly seated. • (Trained service technician only) The microprocessor is correctly installed. 3. If you just installed an optional device, remove it, and restart the server. If the server now starts, you might have installed more devices than the power supply supports. 4. Reseat the following components: <ol style="list-style-type: none"> a. DIMMs b. (Trained service technician only) Power-supply cables to all internal components c. (Trained service technician only) Power connector on the system board 5. Replace the following components one at a time, in the order shown, restarting the server each time: <ol style="list-style-type: none"> a. DIMMs b. (Trained service technician only) Power supply c. (Trained service technician only) System board 6. See “Solving undetermined problems” in the <i>Problem Determination and Service Guide</i>.
<p>The server does not turn off.</p>	<ol style="list-style-type: none"> 1. Determine whether you are using an Advanced Configuration and Power Interface (ACPI) or a non-ACPI operating system. If you are using a non-ACPI operating system, complete the following steps: <ol style="list-style-type: none"> a. Press Ctrl+Alt+Delete. b. Turn off the server by pressing the power-control button for 5 seconds. c. Restart the server. d. If the server fails POST and the power-control button does not work, disconnect the ac power cord for 20 seconds; then, reconnect the ac power cord and restart the server. 2. If the problem remains or if you are using an ACPI-aware operating system, suspect the system board.
<p>The server unexpectedly shuts down, and the LEDs on the operator information panel are not lit.</p>	<p>Call for service.</p>

Serial port problems

<ul style="list-style-type: none"> Follow the suggested actions in the order in which they are listed in the Action column until the problem is solved. See the parts listing in the <i>Problem Determination and Service Guide</i> to determine which components are customer replaceable units (CRU) and which components are field replaceable units (FRU). If an action step is preceded by “(Trained service technician only),” that step must be performed only by a trained service technician. 	
Symptom	Action
The number of serial ports that are identified by the operating system is less than the number of installed serial ports.	<ol style="list-style-type: none"> Make sure that: <ul style="list-style-type: none"> Each port is assigned a unique address in the Configuration/Setup Utility program and none of the serial ports are disabled. The serial-port adapter (if one is installed) is seated correctly. Reseat the serial port adapter. Replace the serial port adapter.
A serial device does not work.	<ol style="list-style-type: none"> Make sure that: <ul style="list-style-type: none"> The device is compatible with the server. The serial port is enabled and is assigned a unique address. The device is connected to the correct connector (see “Rear view” on page 22). Reseat the following components: <ol style="list-style-type: none"> Failing serial device Serial cable Replace the following components one at a time, in the order shown, restarting the server each time: <ol style="list-style-type: none"> Failing serial device Serial cable (Trained service technician only) System board

ServerGuide problems

<ul style="list-style-type: none"> Follow the suggested actions in the order in which they are listed in the Action column until the problem is solved. See the parts listing in the <i>Problem Determination and Service Guide</i> to determine which components are customer replaceable units (CRU) and which components are field replaceable units (FRU). If an action step is preceded by “(Trained service technician only),” that step must be performed only by a trained service technician. 	
Symptom	Action
The <i>ServerGuide Setup and Installation</i> CD will not start.	<ol style="list-style-type: none"> Make sure that the server supports the ServerGuide program and has a startable (bootable) CD or DVD drive. If the startup (boot) sequence settings have been changed, make sure that the CD or DVD drive is first in the startup sequence. If more than one CD or DVD drive is installed, make sure that only one drive is set as the primary drive. Start the CD from the primary drive.
The ServeRAID program cannot view all installed drives, or the operating system cannot be installed.	<ol style="list-style-type: none"> Make sure that there are no duplicate or IRQ assignments. Make sure that the hard disk drive is connected correctly. Make sure that the hard disk drive cables are securely connected.

<ul style="list-style-type: none"> • Follow the suggested actions in the order in which they are listed in the Action column until the problem is solved. • See the parts listing in the <i>Problem Determination and Service Guide</i> to determine which components are customer replaceable units (CRU) and which components are field replaceable units (FRU). • If an action step is preceded by “(Trained service technician only),” that step must be performed only by a trained service technician. 	
Symptom	Action
The operating-system installation program continuously loops.	Make more space available on the hard disk.
The ServerGuide program will not start the operating-system CD.	Make sure that the operating-system CD is supported by the ServerGuide program. See the <i>ServerGuide Setup and Installation</i> CD label for a list of supported operating-system versions.
The operating system cannot be installed; the optional device is not available.	Make sure that the server supports the operating system. If it does, no logical drive is defined (RAID servers). Run the ServerGuide program and make sure that setup is complete.

Software problems

<ul style="list-style-type: none"> • Follow the suggested actions in the order in which they are listed in the Action column until the problem is solved. • See the parts listing in the <i>Problem Determination and Service Guide</i> to determine which components are customer replaceable units (CRU) and which components are field replaceable units (FRU). • If an action step is preceded by “(Trained service technician only),” that step must be performed only by a trained service technician. 	
Symptom	Action
You suspect a software problem.	<ol style="list-style-type: none"> 1. To determine whether the problem is caused by the software, make sure that: <ul style="list-style-type: none"> • The server has the minimum memory that is needed to use the software. For memory requirements, see the information that comes with the software. If you have just installed an adapter or memory, the server might have a memory-address conflict. • The software is designed to operate on the server. • Other software works on the server. • The software works on another server. 2. If you received any error messages when using the software, see the information that comes with the software for a description of the messages and suggested solutions to the problem. 3. Contact your place of purchase of the software.

Universal Serial Bus (USB) port problems

- Follow the suggested actions in the order in which they are listed in the Action column until the problem is solved.
- See the parts listing in the *Problem Determination and Service Guide* to determine which components are customer replaceable units (CRU) and which components are field replaceable units (FRU).
- If an action step is preceded by “(Trained service technician only),” that step must be performed only by a trained service technician.

Symptom	Action
A USB device does not work.	<ol style="list-style-type: none">1. Make sure that:<ul style="list-style-type: none">• The correct USB device driver is installed.• The operating system supports USB devices.• A standard PS/2 keyboard or mouse is not connected to the server. If it is, a USB keyboard or mouse will not work during POST.2. Make sure that the USB configuration options are set correctly in the Configuration/Setup Utility program menu (see the <i>User's Guide</i> for more information).3. If you are using a USB hub, disconnect the USB device from the hub and connect it directly to the server.

Video problems

See “Monitor problems” on page 41.

Appendix A. Getting help and technical assistance

If you need help, service, or technical assistance or just want more information about IBM products, you will find a wide variety of sources available from IBM to assist you. This appendix contains information about where to go for additional information about IBM and IBM products, what to do if you experience a problem with your system or optional device, and whom to call for service, if it is necessary.

Before you call

Before you call, make sure that you have taken these steps to try to solve the problem yourself:

- Check all cables to make sure that they are connected.
- Check the power switches to make sure that the system and any optional devices are turned on.
- Use the troubleshooting information in your system documentation, and use the diagnostic tools that come with your system. Information about diagnostic tools is in the *Hardware Maintenance Manual and Troubleshooting Guide* or *Problem Determination and Service Guide* on the IBM Documentation CD that comes with your system.

Note: For some IntelliStation models, the *Hardware Maintenance Manual and Troubleshooting Guide* is available only from the IBM support Web site.

- Go to the IBM support Web site at <http://www.ibm.com/servers/eserver/support/xseries/index.html> to check for technical information, hints, tips, and new device drivers or to submit a request for information.

You can solve many problems without outside assistance by following the troubleshooting procedures that IBM provides in the online help or in the documentation that is provided with your IBM product. The documentation that comes with IBM systems also describes the diagnostic tests that you can perform. Most systems, operating systems, and programs come with documentation that contains troubleshooting procedures and explanations of error messages and error codes. If you suspect a software problem, see the documentation for the operating system or program.

Using the documentation

Information about your IBM system and preinstalled software, if any, or optional device is available in the documentation that comes with the product. That documentation can include printed documents, online documents, readme files, and help files. See the troubleshooting information in your system documentation for instructions for using the diagnostic programs. The troubleshooting information or the diagnostic programs might tell you that you need additional or updated device drivers or other software. IBM maintains pages on the World Wide Web where you can get the latest technical information and download device drivers and updates. To access these pages, go to <http://www.ibm.com/servers/eserver/support/xseries/index.html> and follow the instructions. Also, some documents are available through the IBM Publications Center at <http://www.ibm.com/shop/publications/order/>.

Getting help and information from the World Wide Web

On the World Wide Web, the IBM Web site has up-to-date information about IBM systems, optional devices, services, and support. The address for IBM System x and xSeries information is <http://www.ibm.com/systems/x/>. The address for IBM IntelliStation information is <http://www.ibm.com/intellistation/>.

You can find service information for IBM systems and optional devices at <http://www.ibm.com/servers/eserver/support/xseries/index.html>.

Software service and support

Through IBM Support Line, you can get telephone assistance, for a fee, with usage, configuration, and software problems with System x and xSeries servers, BladeCenter products, IntelliStation workstations, and appliances. For information about which products are supported by Support Line in your country or region, see <http://www.ibm.com/services/sl/products/>.

For more information about Support Line and other IBM services, see <http://www.ibm.com/services/>, or see <http://www.ibm.com/planetwide/> for support telephone numbers. In the U.S. and Canada, call 1-800-IBM-SERV (1-800-426-7378).

Hardware service and support

Important: When you call for service, you will be asked to provide the four-digit machine type of your system, which is 4364 or 4365.

You can receive hardware service through IBM Services or through your IBM reseller, if your reseller is authorized by IBM to provide warranty service. See <http://www.ibm.com/planetwide/> for support telephone numbers, or in the U.S. and Canada, call 1-800-IBM-SERV (1-800-426-7378).

In the U.S. and Canada, hardware service and support is available 24 hours a day, 7 days a week. In the U.K., these services are available Monday through Friday, from 9 a.m. to 6 p.m.

IBM Taiwan product service

台灣IBM 產品服務聯絡方式：
台灣國際商業機器股份有限公司
台北市松仁路7號3樓
電話：0800-016-888

IBM Taiwan product service contact information:

IBM Taiwan Corporation
3F, No 7, Song Ren Rd.
Taipei, Taiwan
Telephone: 0800-016-888

Appendix B. Notices

This information was developed for products and services offered in the U.S.A.

IBM may not offer the products, services, or features discussed in this document in other countries. Consult your local IBM representative for information on the products and services currently available in your area. Any reference to an IBM product, program, or service is not intended to state or imply that only that IBM product, program, or service may be used. Any functionally equivalent product, program, or service that does not infringe any IBM intellectual property right may be used instead. However, it is the user's responsibility to evaluate and verify the operation of any non-IBM product, program, or service.

IBM may have patents or pending patent applications covering subject matter described in this document. The furnishing of this document does not give you any license to these patents. You can send license inquiries, in writing, to:

*IBM Director of Licensing
IBM Corporation
North Castle Drive
Armonk, NY 10504-1785
U.S.A.*

INTERNATIONAL BUSINESS MACHINES CORPORATION PROVIDES THIS PUBLICATION "AS IS" WITHOUT WARRANTY OF ANY KIND, EITHER EXPRESS OR IMPLIED, INCLUDING, BUT NOT LIMITED TO, THE IMPLIED WARRANTIES OF NON-INFRINGEMENT, MERCHANTABILITY OR FITNESS FOR A PARTICULAR PURPOSE. Some states do not allow disclaimer of express or implied warranties in certain transactions, therefore, this statement may not apply to you.

This information could include technical inaccuracies or typographical errors. Changes are periodically made to the information herein; these changes will be incorporated in new editions of the publication. IBM may make improvements and/or changes in the product(s) and/or the program(s) described in this publication at any time without notice.

Any references in this information to non-IBM Web sites are provided for convenience only and do not in any manner serve as an endorsement of those Web sites. The materials at those Web sites are not part of the materials for this IBM product, and use of those Web sites is at your own risk.

IBM may use or distribute any of the information you supply in any way it believes appropriate without incurring any obligation to you.

Trademarks

The following terms are trademarks of International Business Machines Corporation in the United States, other countries, or both:

Active Memory	IBM	TechConnect
Active PCI	IBM (logo)	Tivoli
Active PCI-X	IntelliStation	Tivoli Enterprise
AIX	NetBAY	Update Connector
Alert on LAN	Netfinity	Wake on LAN

BladeCenter	Predictive Failure Analysis	XA-32
Chipkill	ServeRAID	XA-64
e-business logo	ServerGuide	X-Architecture
@server	ServerProven	XpandOnDemand
FlashCopy	System x	xSeries
i5/OS		

Intel, Intel Xeon, Itanium, and Pentium are trademarks or registered trademarks of Intel Corporation or its subsidiaries in the United States and other countries.

Microsoft, Windows, and Windows NT are trademarks of Microsoft Corporation in the United States, other countries, or both.

UNIX is a registered trademark of The Open Group in the United States and other countries.

Java and all Java-based trademarks and logos are trademarks of Sun Microsystems, Inc. in the United States, other countries, or both.

Adaptec and HostRAID are trademarks of Adaptec, Inc., in the United States, other countries, or both.

Linux is a trademark of Linus Torvalds in the United States, other countries, or both.

Red Hat, the Red Hat “Shadow Man” logo, and all Red Hat-based trademarks and logos are trademarks or registered trademarks of Red Hat, Inc., in the United States and other countries.

Other company, product, or service names may be trademarks or service marks of others.

Important notes

Processor speeds indicate the internal clock speed of the microprocessor; other factors also affect application performance.

CD drive speeds list the variable read rate. Actual speeds vary and are often less than the maximum possible.

When referring to processor storage, real and virtual storage, or channel volume, KB stands for approximately 1000 bytes, MB stands for approximately 1 000 000 bytes, and GB stands for approximately 1 000 000 000 bytes.

When referring to hard disk drive capacity or communications volume, MB stands for 1 000 000 bytes, and GB stands for 1 000 000 000 bytes. Total user-accessible capacity may vary depending on operating environments.

Maximum internal hard disk drive capacities assume the replacement of any standard hard disk drives and population of all hard disk drive bays with the largest currently supported drives available from IBM.

Maximum memory may require replacement of the standard memory with an optional memory module.

IBM makes no representation or warranties regarding non-IBM products and services that are ServerProven[®], including but not limited to the implied warranties of merchantability and fitness for a particular purpose. These products are offered and warranted solely by third parties.

IBM makes no representations or warranties with respect to non-IBM products. Support (if any) for the non-IBM products is provided by the third party, not IBM.

Some software may differ from its retail version (if available), and may not include user manuals or all program functionality.

Product recycling and disposal

This unit must be recycled or discarded according to applicable local and national regulations. IBM encourages owners of information technology (IT) equipment to responsibly recycle their equipment when it is no longer needed. IBM offers a variety of product return programs and services in several countries to assist equipment owners in recycling their IT products. Information on IBM product recycling offerings can be found on IBM's Internet site at <http://www.ibm.com/ibm/environment/products/prp.shtml>.

Esta unidad debe reciclarse o desecharse de acuerdo con lo establecido en la normativa nacional o local aplicable. IBM recomienda a los propietarios de equipos de tecnología de la información (TI) que reciclen responsablemente sus equipos cuando éstos ya no les sean útiles. IBM dispone de una serie de programas y servicios de devolución de productos en varios países, a fin de ayudar a los propietarios de equipos a reciclar sus productos de TI. Se puede encontrar información sobre las ofertas de reciclado de productos de IBM en el sitio web de IBM <http://www.ibm.com/ibm/environment/products/prp.shtml>.

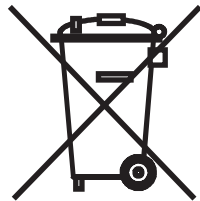

Notice: This mark applies only to countries within the European Union (EU) and Norway.

This appliance is labeled in accordance with European Directive 2002/96/EC concerning waste electrical and electronic equipment (WEEE). The Directive determines the framework for the return and recycling of used appliances as applicable throughout the European Union. This label is applied to various products to indicate that the product is not to be thrown away, but rather reclaimed upon end of life per this Directive.

注意: このマークは EU 諸国およびノルウェーにおいてのみ適用されます。

この機器には、EU 諸国に対する廃電気電子機器指令 2002/96/EC(WEEE) のラベルが貼られています。この指令は、EU 諸国に適用する使用済み機器の回収とリサイクルの骨子を定めています。このラベルは、使用済みになった時に指令に従って適正な処理をする必要があることを知らせるために種々の製品に貼られています。

Remarque : Cette marque s'applique uniquement aux pays de l'Union Européenne et à la Norvège.

L'étiquette du système respecte la Directive européenne 2002/96/EC en matière de Déchets des Equipements Electriques et Electroniques (DEEE), qui détermine les dispositions de retour et de recyclage applicables aux systèmes utilisés à travers l'Union européenne. Conformément à la directive, ladite étiquette précise que le produit sur lequel elle est apposée ne doit pas être jeté mais être récupéré en fin de vie.

In accordance with the European WEEE Directive, electrical and electronic equipment (EEE) is to be collected separately and to be reused, recycled, or recovered at end of life. Users of EEE with the WEEE marking per Annex IV of the WEEE Directive, as shown above, must not dispose of end of life EEE as unsorted municipal waste, but use the collection framework available to customers for the return, recycling, and recovery of WEEE. Customer participation is important to minimize any potential effects of EEE on the environment and human health due to the potential presence of hazardous substances in EEE. For proper collection and treatment, contact your local IBM representative.

Battery return program

This product may contain a sealed lead acid, nickel cadmium, nickel metal hydride, lithium, or lithium ion battery. Consult your user manual or service manual for specific battery information. The battery must be recycled or disposed of properly. Recycling facilities may not be available in your area. For information on disposal of batteries outside the United States, go to <http://www.ibm.com/ibm/environment/products/batteryrecycle.shtml> or contact your local waste disposal facility.

In the United States, IBM has established a return process for reuse, recycling, or proper disposal of used IBM sealed lead acid, nickel cadmium, nickel metal hydride, and battery packs from IBM equipment. For information on proper disposal of these batteries, contact IBM at 1-800-426-4333. Have the IBM part number listed on the battery available prior to your call.

For Taiwan: Please recycle batteries.



For the European Union:



For California: Perchlorate material – special handling may apply. See <http://www.dtsc.ca.gov/hazardouswaste/perchlorate/>.

The foregoing notice is provided in accordance with California Code of Regulations Title 22, Division 4.5 Chapter 33. Best Management Practices for Perchlorate Materials. This product/part may include a lithium manganese dioxide battery which contains a perchlorate substance.

Electronic emission notices

Federal Communications Commission (FCC) statement

Note: This equipment has been tested and found to comply with the limits for a Class A digital device, pursuant to Part 15 of the FCC Rules. These limits are designed to provide reasonable protection against harmful interference when the equipment is operated in a commercial environment. This equipment generates, uses, and can radiate radio frequency energy and, if not installed and used in accordance with the instruction manual, may cause harmful interference to radio communications. Operation of this equipment in a residential area is likely to cause harmful interference, in which case the user will be required to correct the interference at his own expense.

Properly shielded and grounded cables and connectors must be used in order to meet FCC emission limits. IBM is not responsible for any radio or television interference caused by using other than recommended cables and connectors or by unauthorized changes or modifications to this equipment. Unauthorized changes or modifications could void the user's authority to operate the equipment.

This device complies with Part 15 of the FCC Rules. Operation is subject to the following two conditions: (1) this device may not cause harmful interference, and (2) this device must accept any interference received, including interference that may cause undesired operation.

Industry Canada Class A emission compliance statement

This Class A digital apparatus complies with Canadian ICES-003.

Avis de conformité à la réglementation d'Industrie Canada

Cet appareil numérique de la classe A est conforme à la norme NMB-003 du Canada.

Australia and New Zealand Class A statement

Attention: This is a Class A product. In a domestic environment this product may cause radio interference in which case the user may be required to take adequate measures.

United Kingdom telecommunications safety requirement

Notice to Customers

This apparatus is approved under approval number NS/G/1234/J/100003 for indirect connection to public telecommunication systems in the United Kingdom.

European Union EMC Directive conformance statement

This product is in conformity with the protection requirements of EU Council Directive 89/336/EEC on the approximation of the laws of the Member States relating to electromagnetic compatibility. IBM cannot accept responsibility for any failure to satisfy the protection requirements resulting from a nonrecommended modification of the product, including the fitting of non-IBM option cards.

This product has been tested and found to comply with the limits for Class A Information Technology Equipment according to CISPR 22/European Standard EN 55022. The limits for Class A equipment were derived for commercial and industrial environments to provide reasonable protection against interference with licensed communication equipment.

Attention: This is a Class A product. In a domestic environment this product may cause radio interference in which case the user may be required to take adequate measures.

Taiwanese Class A warning statement

警告使用者：
這是甲類的資訊產品，在居住的環境中使用時，可能會造成射頻干擾，在這種情況下，使用者會被要求採取某些適當的對策。

Chinese Class A warning statement

聲 明
此為 A 級產品。在生活環境中，該產品可能會造成無線電干擾。在這種情況下，可能需要用戶對其干擾採取切實可行的措施。

Japanese Voluntary Control Council for Interference (VCCI) statement

この装置は、情報処理装置等電波障害自主規制協議会（VCCI）の基準に基づくクラスA情報技術装置です。この装置を家庭環境で使用すると電波妨害を引き起こすことがあります。この場合には使用者が適切な対策を講ずるよう要求されることがあります。

Index

A

- adapter
 - installing 13
 - types supported 13
- attention notices 3

B

- baseboard management controller (BMC)
 - functions 27
- bays 4
- beep codes 29

C

- caution statements 3
- CD drive
 - problems 37
- CD-eject button 21
- CD/DVD drive
 - activity LED 21
 - specification 4
- Class A electronic emission notice 55
- Configuration/Setup Utility program 26
- configuring
 - hot-swap SAS or SATA devices 26
 - SAS/SATA controller 26
- configuring hardware 25
- connectors 22
 - front 19
 - optional devices 6
 - rear 19
- controller
 - Ethernet
 - configuring 20
 - type 4
 - hard disk drive 4
 - SAS 4
 - SATA 4
 - video 4
- cover
 - installing 18
 - removing 9

D

- danger statements 3
- DIMMs
 - connector locations 10
 - supported 4
- display problems 41
- documentation CD 2
- drives 4
- DVD drive problems 37

E

- electrical input 4
- electronic emission Class A notice 55
- environment 4
- error messages, POST 30
- error symptoms
 - CD-ROM drive, DVD-ROM drive 37
 - general 38
 - hard disk drive 38
 - intermittent 39
 - keyboard, non-USB 39
 - memory 40
 - microprocessor 41
 - monitor 41
 - mouse, non-USB 39
 - optional devices 44
 - pointing device, non-USB 39
 - power 45
 - serial port 46
 - software 47
 - USB port 48
- Ethernet
 - connector 22
 - controller
 - configuring 20
 - type 4
 - speed indicator 22
 - speed LED 22
 - transmit/receive activity LED 22
- expansion bays 4
- expansion slots 4

F

- FCC Class A notice 55
- features 4
- firmware updates 1

H

- hard disk drive
 - activity LED 21
 - hot-swap SATA 12
 - installing 11
 - problems 38
 - removing 12
 - SAS 11, 12
 - SCSI
 - See SAS
 - Serial ATA 11
- heat output 4
- humidity 4

I

- important notices 3
- installation order, memory modules 10

- installing
 - adapters 13
 - cover 18
 - DIMMs 9
 - hard disk drives 11
- integrated
 - controllers 4
 - functions 4
- intermittent problems 39

K

- keyboard connector 22
- keyboard problems 39

L

- LED
 - cd drive activity 21
 - Ethernet speed 22
 - Ethernet transmit/receive activity 22
 - hard disk drive activity 21
 - locator 21
 - power-on 21
 - system error 21
- LEDs
 - front 21
 - rear 22
- locator LED 21

M

- major components 5
- memory
 - installing 9
 - order of installation 10
 - specifications 4
- memory module
 - installation 10
 - specifications 10
- memory problems 40
- microprocessor
 - problems 41
 - type 4
- monitor problems 41
- mouse connector 22

N

- noise emissions 4
- notes 3
- notes, important 52
- notices
 - electronic emission 55
 - FCC, Class A 55
- notices and statements 3

O

- online documentation 1
- optional device problems 44
- optional-device connectors 6
- order of installation, memory modules 10

P

- POST error messages 30
- power
 - problems 45
 - requirement 4
 - supply 4
- power-control
 - button 21
 - button shield 21
- power-cord connector 22
- power-on LED 21
- problems
 - CD-ROM, DVD-ROM drive 37
 - hard disk drive 38
 - intermittent 39
 - memory 40
 - microprocessor 41
 - monitor 41
 - mouse 39, 40
 - optional devices 44
 - pointing device 40
 - power 45
 - serial port 46
 - software 47
 - solving 29
 - USB port 48
 - video 48

R

- reset button 21
- riser card
 - connector location 6
 - removing 15
 - slots 6

S

- SAS
 - hard disk drives, installing 12
 - hot-swap drives 4
 - hot-swap models 4
- SATA
 - hot-swap 4
 - hot-swap hard disk drives, installing 12
 - simple-swap 4
 - simple-swap hard disk drives, installing 11
- serial connector 22
- serial port problems 46
- serial-attached SCSI
 - See SAS
- ServerGuide
 - CD 25

ServerGuide (*continued*)
 error symptoms 46
 using 25
simple-swap Serial ATA hard disk drive 11
size 4
slot locations, PCI Express 6
slots 4
software problems 47
solving problems 29
specifications 4
Standby mode 23
statements and notices 3
system board connectors 6
System x Web address 1
system-error LED 21
systems-management connector 22

T

temperature 4
trademarks 51
troubleshooting chart 37
turning off the server 23
turning on the server 23

U

United States electronic emission Class A notice 55
United States FCC Class A notice 55
Universal Serial Bus (USB) problems 48
USB connector 21, 22
utility program
 Configuration/Setup 26
 LSI Logic Configuration Utility program 26
 SAS configuration 26

V

video connector 22
video controller 4

W

weight 4



Part Number: 42C5004

Printed in USA

(1P) P/N: 42C5004

